

Bureau

Structure bureau

Composé d'un élément central et d'un panneau latéral.

Élément central: composé d'un châssis structurel constitué de plaques métalliques découpées au laser (3 plaques de 10 mm d'ép. et 2 plaques de 5 mm d'ép.) et de deux tubes métalliques de 2 mm d'ép. et de 30x20 mm de section, soudés entre eux pour former une sorte de boîte. Dans la partie inférieure, 4/6 pieds de réglage (+10 mm) sont fixés pour la mise à niveau du sol.

Le châssis structurel est recouvert de panneaux de finition en:

- **plaqué:** réalisé en aggloméré ép. 22 mm pour le panneau latéral et ép. 12 mm pour les panneaux frontaux (densité 720 kg/m³, classe d'émission de formaldéhyde E1, conforme aux exigences CARB), plaqué sur les deux côtés avec un placage en bois naturel et peint sur les côtés visibles. Les panneaux sont bordés en bois (1 mm d'épaisseur).

- **Fenix:** réalisé en aggloméré ép. 22 mm d'épaisseur pour les panneaux latéraux et de 10 mm pour les panneaux frontaux (densité 720 kg/m³, classe d'émission de formaldéhyde E1, conforme aux exigences CARB), revêtu sur le côté visible de Fenix NTM, ép. 0,9 mm, et sur le côté non visible de stratifié haute pression HPL (d'une épaisseur de 0,9 mm pour les panneaux latéraux et de 0,5 mm pour les panneaux frontaux). Les panneaux sont bordés d'ABS, d'une épaisseur de 1 mm, avec des bords arrondis.

L'épaisseur totale de l'élément central est de 15 cm.

Selon le type de bureau, fixe ou réglable en hauteur, deux colonnes sont fixées à l'intérieur du châssis structurel à l'aide de vis métriques. Les colonnes peuvent l'être:

- **fixe:** composé de 2 tubes métalliques de 2 mm d'ép., d'une section de 70x70 mm, à l'extrémité desquels sont soudées deux plaques;

- **réglable en hauteur:** composé de 2 tubes à section carrée (70x70 mm) qui permettent une hauteur de 40 cm. Ils sont fixés au châssis structurel à l'aide de vis métriques.

Des plaques métalliques de 5 mm d'épaisseur, de section rectangulaire 40x30 cm, sont fixées aux colonnes pour soutenir la plateforme.

Toutes les parties métalliques sont peintes à la poudre époxy avec une finition gaufrée en noir RAL 9005.

Panneau latéral:

- **plaqué:** en aggloméré de 22 mm d'épaisseur (densité 720 kg/m³, classe d'émission de formaldéhyde E1, conforme aux exigences CARB), plaqué sur les deux côtés avec du bois naturel et peint sur les côtés visibles. Le panneau est bordé de bois (1 mm d'épaisseur).

- **Fenix:** panneau de particules de 22 mm d'épaisseur (densité 720 kg/m³, classe d'émission de formaldéhyde E1, conforme aux exigences CARB), revêtu sur le côté visible de Fenix NTM, d'une épaisseur de 0,9 mm, et sur le côté non visible de stratifié haute pression HPL (0,9 mm d'épaisseur). Le panneau est bordé d'ABS, d'une épaisseur de 1 mm, avec des bords arrondis.

Le panneau latéral est fixé à l'élément central au moyen de vis métriques.

Plateaux du bureau

- **plaqué:** panneau à double âme en MDF avec intérieur en sapin (densité 530 kg/m³, classe d'émission de formaldéhyde E1, conforme aux exigences CARB), plaqué sur les deux côtés avec un placage en bois naturel, verni sur les côtés visibles et avec un chant en bois (1 mm d'épaisseur). L'épaisseur totale du plateau est de 51 mm

- **Fenix:** panneau à double âme en MDF avec intérieur en sapin (densité 530 kg/m³, classe d'émission de formaldéhyde E1, conforme aux exigences CARB), revêtu sur le côté visible de Fenix NTM de 0,9 mm d'épaisseur et sur le côté non visible d'un stratifié haute pression (HPL) de 0,9 mm d'épaisseur. Il est bordé d'ABS de 1 mm d'épaisseur avec des bords arrondis. L'épaisseur totale du plateau est de 52 mm.

Dans le cas des bureaux fixes, le plateau est fixé aux plaques et au panneau latéral. Dans le cas des bureaux réglables en hauteur, le plateau est fixé aux plaques uniquement.

Console

Structure du console

Composé d'un élément central et d'un panneau latéral.

L'élément central peut être réalisé en:

- **Fenix:** panneau à double âme en MDF avec intérieur en sapin (densité 530 kg/m³, classe d'émission de formaldéhyde E1, conforme aux exigences CARB), d'une épaisseur de 50 mm, plaqué sur les deux faces de Fenix NTM d'une épaisseur de 0,9 mm et bordé d'ABS d'une épaisseur de 1 mm avec des bords arrondis.

- **Oleomalta:** constitué d'un panneau à double âme en MDF avec intérieur en sapin (densité 530 kg/m³, classe d'émission de formaldéhyde E1, conforme aux exigences CARB), d'une épaisseur de 50 mm, bordé d'ABS d'une épaisseur de 1 mm avec des bords arrondis. Sur ce panneau est appliqué Oleomalta, un monocomposant à base d'eau avec des polymères synthétiques, de l'huile de tournesol et un mix de sable, produit à froid pour contribuer à la réduction des émissions de CO2. Les charges minérales utilisées sont d'origine italienne et proviennent de zones de production proches. Il ne développe pas de gaz toxiques pour l'environnement ou le sous-sol, ne contient pas de traces de NMP (N-méthyl Pyrrolidone - solvant), est antibactérien et antiviral, et est un purificateur naturel de l'air ambiant.

- **quartz:** composé d'un cœur interne en mousse fabriqué en polymère de polyuréthane rigide thermodurcissable, recouvert de panneaux de quartz de 20 mm d'épaisseur réalisés en résine de polyester structurelle et de pigments colorés stabilisés aux UV.

- **cuir:** en aggloméré de 38 mm d'épaisseur (densité 720 kg/m³, classe d'émission de formaldéhyde E1, conforme aux exigences CARB) sur lequel est collée une feuille de faésite de 3 mm d'épaisseur sur les surfaces visibles, revêtue de cuir.

Le panneau latéral peut être réalisé en:

- **Fenix:** en aggloméré de 22 mm d'épaisseur (densité 720 kg/m³, classe d'émission de formaldéhyde E1, conforme aux exigences CARB), revêtu sur le côté visible de Fenix NTM, d'une épaisseur de 0,9 mm, et sur le côté non visible de stratifié haute pression HPL (d'une épaisseur de 0,9 mm). Le panneau est bordé d'ABS, d'une épaisseur de 1 mm, avec des bords arrondis.

- **Oleomalta:** en aggloméré de 22 épaisseur (densité 720 kg/m³, classe d'émission de formaldéhyde E1, conforme aux exigences CARB), sur lequel est appliqué l'oleomalta.

- **quartz:** composé d'un panneau de particules de 18 mm d'épaisseur (densité 720 kg/m³, classe d'émission de formaldéhyde E1, conforme aux exigences CARB), recouvert de panneaux de quartz de 20 mm d'épaisseur réalisés en résine polyester structurelle et de pigments colorés stabilisés aux UV.

- **cuir:** en aggloméré de 25 mm d'épaisseur (densité 720 kg/m³, classe d'émission de formaldéhyde E1, conforme aux exigences CARB) revêtu en cuir

L'élément central et le panneau latéral sont équipés de pieds de réglage (+10 mm) pour la mise à niveau du sol.

Plateaux du console

- **Fenix:** panneau à double âme en MDF avec intérieur en sapin (densité 530 kg/m³, classe d'émission de formaldéhyde E1, conforme aux exigences CARB), d'une épaisseur de 50 mm, plaqué sur les deux faces de Fenix NTM d'une épaisseur de 0,9 mm et bordé d'ABS d'une épaisseur de 1 mm avec des bords arrondis.

- **Oleomalta:** constitué d'un panneau à double âme en MDF avec intérieur en sapin (densité 530 kg/m³, classe d'émission de formaldéhyde E1, conforme aux exigences CARB), d'une épaisseur de 50 mm, bordé d'ABS d'une épaisseur de 1 mm avec des bords arrondis. Sur ce panneau est appliqué Oleomalta.

- **quartz:** composé d'un cœur interne en mousse fabriqué en polymère de polyuréthane rigide thermodurcissable, recouvert de panneaux de quartz de 20 mm d'épaisseur réalisés en résine de polyester structurelle et de pigments colorés stabilisés aux UV.

- **cuir:** en aggloméré de 45 mm d'épaisseur (densité 720 kg/m³, classe d'émission de formaldéhyde E1, conforme aux exigences CARB) sur lequel est collée une feuille de faésite de 3 mm d'épaisseur sur les surfaces visibles, revêtue de cuir.

Le plateau est fixé à la structure au moyen de plaques métalliques de 10 mm d'épaisseur, revêtues de poudre époxy gaufrée de couleur noire RAL 9005.

Le bureau et la console sont reliés par un système de clips en plastique et de vis métriques.

HELORUS

Scrivania

Desk

Bureau

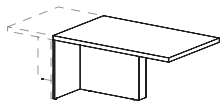

F - Fenix



FEBI - Bianco
White - Blanc



FENE - Nero
Black - Noir

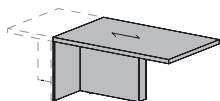

W - Legno - Veneer - Bois

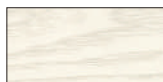

WBI - Frassino bianco
White ash
Frêne blanc



WNS - Noce scuro
Dark walnut
Noyer foncé



WFN - Frassino nero
Black ash
Frêne noir

Consolle

Console

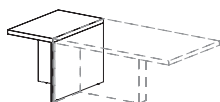

F - Fenix



FEBI - Bianco
White - Blanc



FENE - Nero
Black - Noir

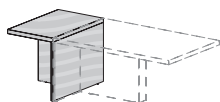

OM - Oleomalta

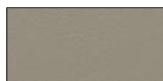

OMGR - Grigio
Grey - Gris



OMNE - Nero
Black - Noir

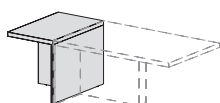

QU - Quarzo - Quartz - Quartz

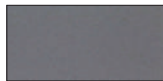

QUGC - Quarzo grigio chiaro
Light grey quartz
Quartz gris clair



QUNE - Quarzo nero nuvola
Cloudy black quartz
Quartz noir nuageux

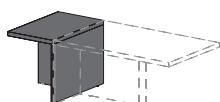

Cat. P - Pelle - Leather - Cuir



Cat. P - Pelle
Leather - Cuir

HELORUS

Carter scrivania elevabile

Height-adjustable desk carter

Carter de bureau réglable en hauteur

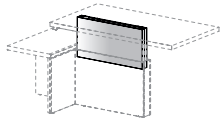

MET - Metallo - Metal - Métal



ZPS - Piombo

satinato

Satin lead

Gris plomb satiné

ZCH - Champagne

Champagne

Champagne

Cassettiera

Pedestal

Caisson

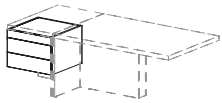

F - Fenix



FEBI - Bianco

White - Blanc

FENE - Nero

Black - Noir

HL - Hpl

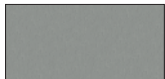

HLPS - Piombo

satinato

Satin lead

Gris plomb satiné

LA - Laccato opaco - Matt lacquered - Laqué mat

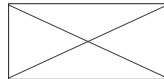
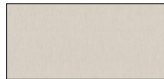

LABI - Bianco

White - Blanc

RAL 9016

LANE - Nero

Black - Noir

RAL 9011

LACH - Champagne

Champagne

Champagne

LA99 - Colore

cliente

Custom color

Couleur personnalisée
client

OM - Oleomalta

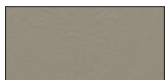

OMGR - Grigio

Grey - Gris

OMNE - Nero

Black - Noir

HELORUS

Mobili di servizio / Madia / Fioriera

Service units / Cupboards / Plant box

Meubles de service / Armoire / Bac à fleur

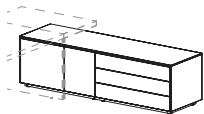

F - Fenix



FEBI - Bianco
White - Blanc



FENE - Nero
Black - Noir

HL - Hpl

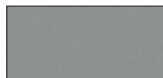

HLPS - Piombo satinato
Satin lead
Gris plomb satiné

LA - Laccato opaco - Matt lacquered - Laqué mat



LABI - Bianco
White - Blanc
RAL 9016



LANE - Nero
Black - Noir
RAL 9011



LACH - Champagne
Champagne
Champagne

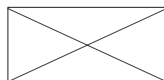

LA99 - Colore cliente
Custom color
Couleur personnalisée client

OM - Oleomalta

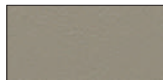

OMGR - Grigio
Grey - Gris



OMNE - Nero
Black - Noir

Cuscino per mobile di servizio

Cushion for service unit

Coussin pour meuble de service

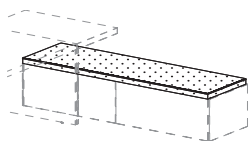

T - Tessuto - Fabric - Tissu



Cat. D



Cat. F

Elemento interno fioriera

Plant box interior element

Élément intérieur du bac à fleur



MET - Metallo - Metal - Métal

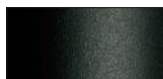

ZGNE - Verniciato goffrato nero
Black embossed painted
Verni gaufré noir
RAL 9005

HELORUS

Mediawall
Mediawall
Mediawall

MET - Struttura in metallo - Metal structure - Structure en métal

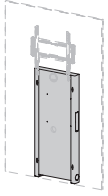

ZGBI - Verniciato goffrato bianco
White embossed painted
Verni gaufré blanc
RAL 9010



ZGNE - Verniciato goffrato nero
Black embossed painted
Verni gaufré noir
RAL 9005

F - Pannello in fenix - Fenix panel - Panneau en fenix

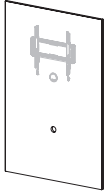

FEBI - Bianco
White - Blanc



FENE - Nero
Black - Noir

W - Pannello in legno - Veneer panel - Panneau en bois

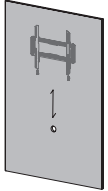

WBI - Frassino bianco
White ash
Frêne blanc



WNS - Noce scuro
Dark walnut
Noyer foncé



WFN - Frassino nero
Black ash
Frêne noir

F - Tavolo in fenix - Fenix table - Table en fenix

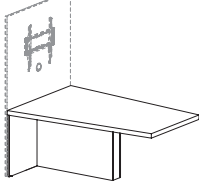

FEBI - Bianco
White - Blanc



FENE - Nero
Black - Noir

W - Tavolo in legno - Veneer table - Table en bois

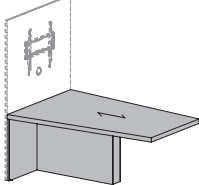

WBI - Frassino bianco
White ash
Frêne blanc

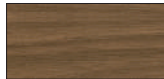

WNS - Noce scuro
Dark walnut
Noyer foncé



WFN - Frassino nero
Black ash
Frêne noir

Mediawall - Staffa VESA per monitor
Mediawall - VESA bracket for monitor
Mediawall - Support VESA pour moniteur

MET - Metallo - Metal - Métal



NE - Nero
Black - Noir

HELORUS

Tavolo riunione

Meeting table

Table réunion

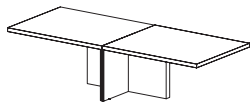

F - Fenix



FEBI - Bianco
White - Blanc



FENE - Nero
Black - Noir

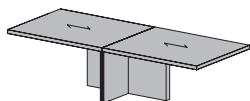

W - Legno - Veneer - Bois

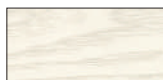

WBI - Frassino bianco
White ash
Frêne blanc



WNS - Noce scuro
Dark walnut
Noyer foncé



WFN - Frassino nero
Black ash
Frêne noir

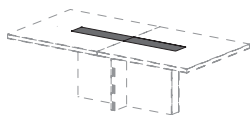

Cat. P - Insetto centrale rivestito in pelle - Upholstered leather central insert - Inset central revêtu en cuir



Cat. P - Pelle
Leather - Cuir

Tavolo conferenza in Fenix

Fenix conference table

Table conference en Fenix

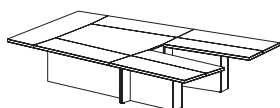

F - Fenix



FEBI - Bianco
White - Blanc



FENE - Nero
Black - Noir

Tavolo conferenza in legno

Veneer conference table

Table conference en bois

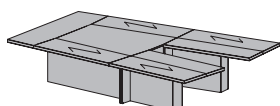

W - Legno - Veneer - Bois



WBI - Frassino bianco
White ash
Frêne blanc



WNS - Noce scuro
Dark walnut
Noyer foncé



WFN - Frassino nero
Black ash
Frêne noir



F - Insetto in Fenix - Fenix insert - Inset en Fenix



FEBI - Bianco
White - Blanc



FENE - Nero
Black - Noir

Vasca raccogliacavi per tavolo conferenza

Cable tray for conference table

Porte-câbles pour table conférence

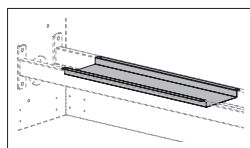

MET - Metallo - Metal - Métal



ZGNE - Verniciato goffrato nero
Black embossed painted
Verni gaufré noir
RAL 9005

HELORUS

Tavolo caffè

Coffee table

Table basse

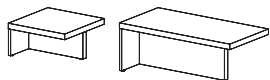

F - Fenix



FEBI - Bianco
White - Blanc



FENE - Nero
Black - Noir

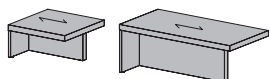

W - Legno - Veneer - Bois

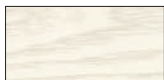

WBI - Frassino bianco
White ash
Frêne blanc



WNS - Noce scuro
Dark walnut
Noyer foncé



WFN - Frassino nero
Black ash
Frêne noir

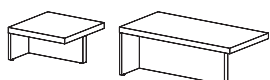

HL - Hpl

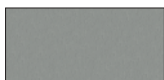

HLPS - Piombo satinato
Satin lead
Gris plomb satiné

LA - Laccato opaco - Matt lacquered - Laqué mat

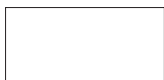

LABI - Bianco
White - Blanc
RAL 9016



LANE - Nero
Black - Noir
RAL 9011

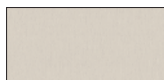

LACH - Champagne
Champagne
Champagne

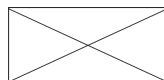

LA99 - Colore cliente
Custom color
Couleur personnalisée
client

HELORUS

Mensola
Shelf
Étagère



F - Fenix



FEBI - Bianco
White - Blanc



FENE - Nero
Black - Noir

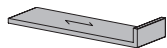

W - Legno - Veneer - Bois

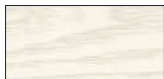

WBI - Frassino bianco
White ash
Frêne blanc



WNS - Noce scuro
Dark walnut
Noyer foncé



WFN - Frassino nero
Black ash
Frêne noir



HL - Hpl



HLPS - Piombo satinato
Satin lead
Gris plomb satiné

HELORUS

Dati tecnici
 Technical data
 Données techniques

Scrivania con consolle
 Desk with console
 Bureau avec console

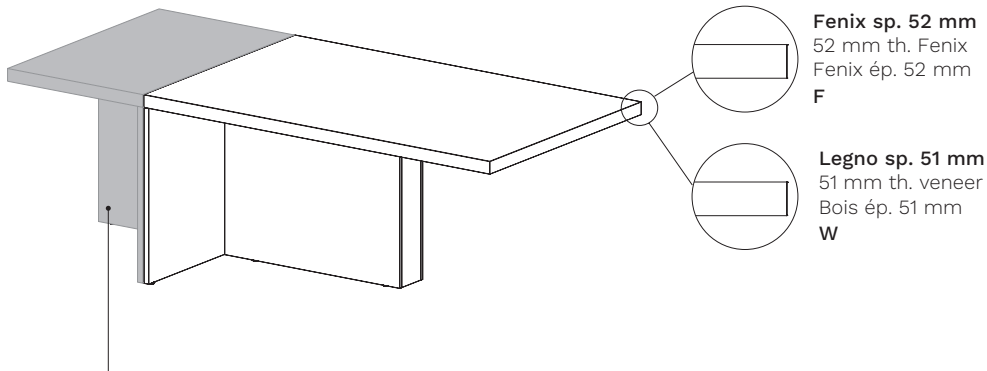

Consolle
 Consolle - Consolle

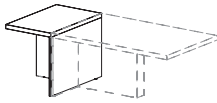

F - Fenix

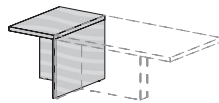

OM - Oleomalta

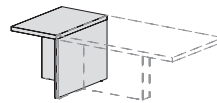

QU - Quarzo
 Quartz - Quartz

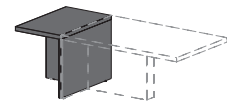

Cat. P - Pelle
 Leather - Cuir

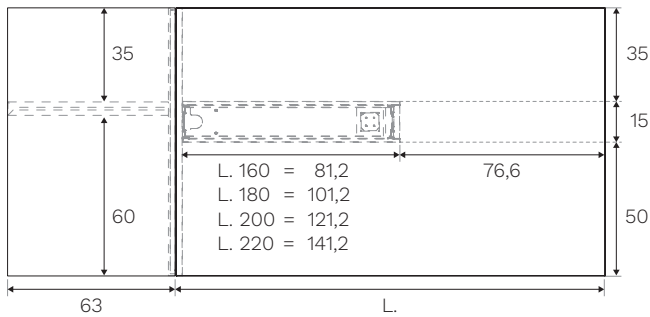

Posizioni VERSALIFT per scrivania
 VERSALIFT positions for desk
 Position du VERSALIFT pour bureau

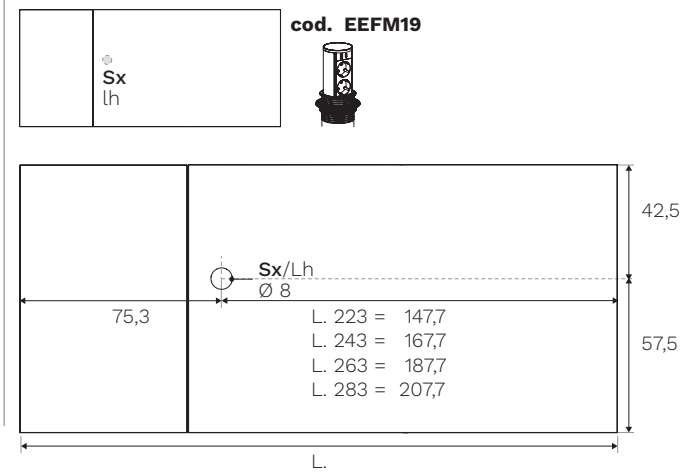
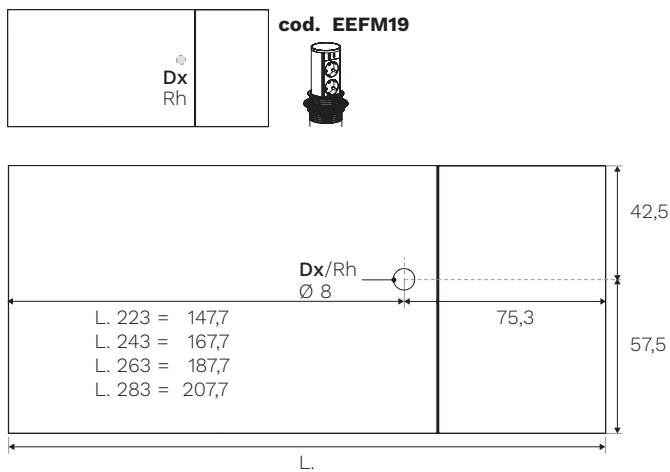

HELORUS

Scrivania elevabile in altezza - Si prega di specificare il tipo di spina (Schuko-UK-US)

Height-adjustable desk - Please specify the type of plug (Schuko-UK-US)

Bureau réglable en hauteur - Veuillez spécifier le type de prise (Schuko-UK-US)

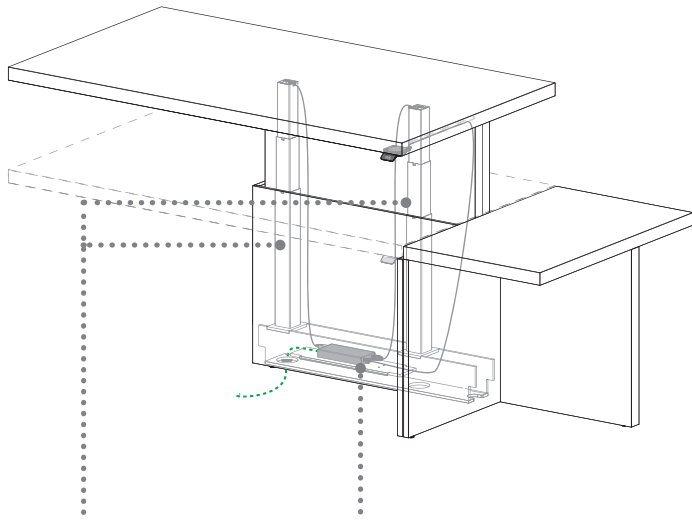

Colonne motorizzate (x2)
Powered column (x2)
Colonnes motorisées (x2)

Centralina di controllo
Control box
Unité de commande

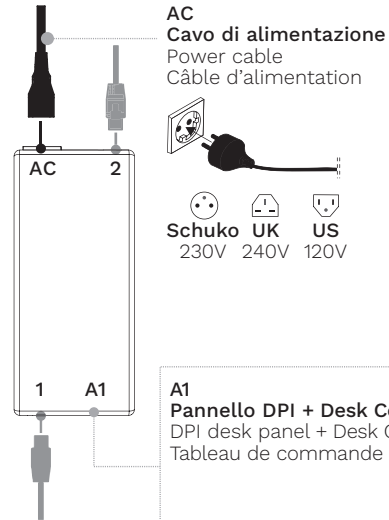

Mux70

Centralina di controllo (EU 230V, UK/US 100-240V)
Control Box (EU 230V, UK/US 100-240V)
Unité de commande (EU 230V, UK/US 100-240V)

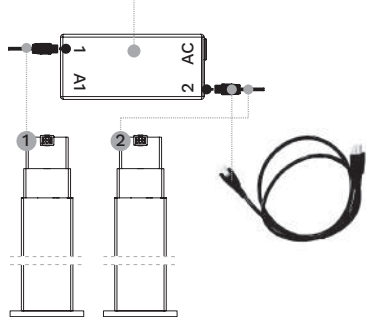

(2x) Colonne motorizzate + (2x) Cavo motore
(2x) Powered columns + (2x) Motor cable
(2x) Colonnes motorisées + (2x) Câble du moteur

HELORUS

Colonne regolabili in altezza

Height-adjustable columns

Colonnes réglables en hauteur

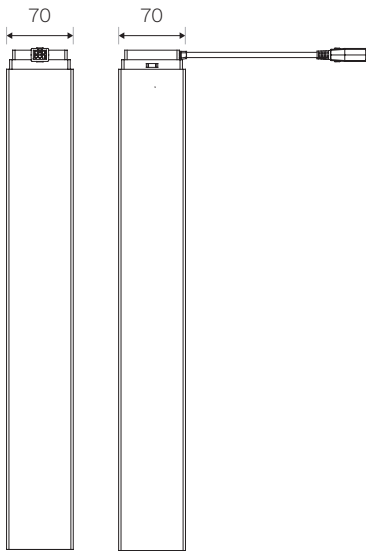

Dati tecnici colonna

Column technical data

Velocità Speed	max 38 mm/s
Lunghezza corsa standard Standard stroke length	400 mm
Peso Weight	8 kg per colonna 8 kg per column
Dimensioni colonna Column dimensions	profilo esterno: 70 mm outer profile: 70 mm
Colore_Color	nero RAL 9005 _ black RAL 9005
Ciclo di lavoro Duty cycle	10% - 1 min. a uso continuo a pieno carico, seguito da 9 minuti di pausa. 10% - 1 min. continuous use at full load, followed by 9 min. pause.
Temperatura d'esercizio Ambient temperature	da +10°C a +40°C from +10°C to +40°C

Pannello DPI

DPI desk panel

Tableau de commande DPI



Centralina di controllo

Control Box

Unité de commande



Caratteristiche DPI

DPI Features

Display con informazioni sullo stato
Display with status information

Azionamento su/giù
Up/down movement

Sistema anti-collisione integrato
Built-in anti-collision sensor

Tecnologia Bluetooth®
Bluetooth Technology

Fino a quattro posizioni
memorizzabili
Up to four favourite positions

Caratteristiche centralina di controllo

Control box features

EU: 230 V
UK - US: 100-240V

Sistema basato su comunicazione a radiofrequenza
System based on radiofrequency communication

HELORUS

Elettrificazione mobile di servizio

Passage of cables for service unit
Électrification du meuble de service

Lato operatore
Operator side
Côte opérateur

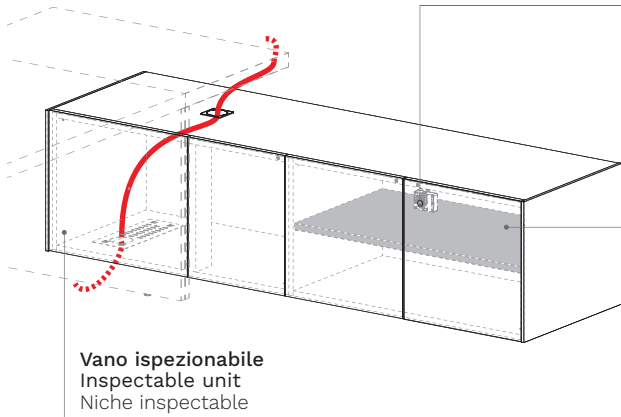

Vano ispezionabile
Inspectable unit
Niche inspectable

+ LOCK - Type D

Serratura con tecnologia a impronta digitale
Lock with fingerprint technology
Serrure à empreinte digitale

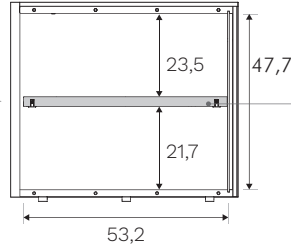
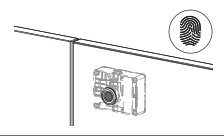

Ripiano fisso sp. 25 mm
25 mm th. fixed shelf
Étagère fixe ép. 25 mm

 **Max 25 kg**
Max 55.12 lb

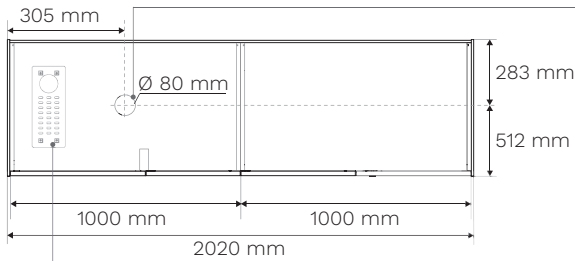

+ APP

Foratura top mobile per 1 VERSALIFT (non incluso)
Drilling for top for 1 VERSALIFT (not included)
Perçage pour dessus pour 1 VERSALIFT (pas inclus)



cod. EEFM19



Griglia uscita cavi

Cable outlet grid
Grille pour sorties de câbles

Mobile di servizio con frigorifero (230V-115V) - Tenere il mobile a 5 cm dal muro per aerazione

Service unit with fridge (230V-115V) - Keep the service unit 5 cm away from the wall to allow air to circulate

Meuble de service avec réfrigérateur (230V-115V) - Le meuble doit être à 5 cm du mur pour permettre la circulation de l'air

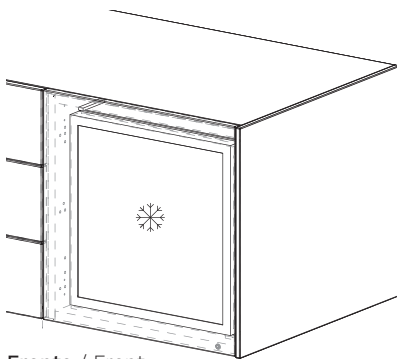

Fronte / Front

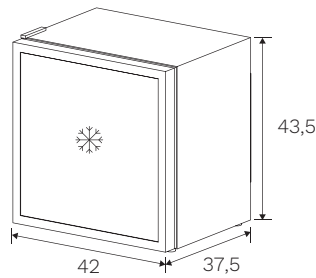

Tenere il mobile a 5 cm dal muro per aerazione

Keep the unit 5 cm away from the wall to allow air to circulate
Le meuble doit être à 5 cm du mur pour permettre la circulation de l'air.

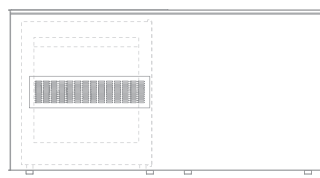
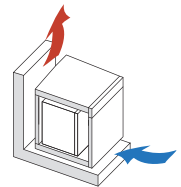

Retro / Back

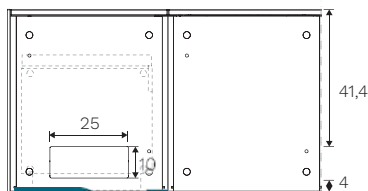

Fondo / Bottom **France Bureau**

Capacità totale Total volume - Volume utile total	25 l
Peso Weight - Poids	12 Kg 26.46 lbs
Tensione di alimentazione Power supply voltage Alimentation	Option 1 : 230 V (50 Hz) Option 2 : 115 V (60 Hz)

HELORUS

Posizione VERSALIFT per tavoli riunione

VERSALIFT position for meeting tables

Position du VERSALIFT pour tables de réunion

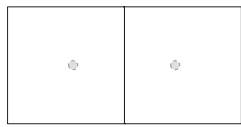

cod. EEFM19

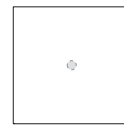
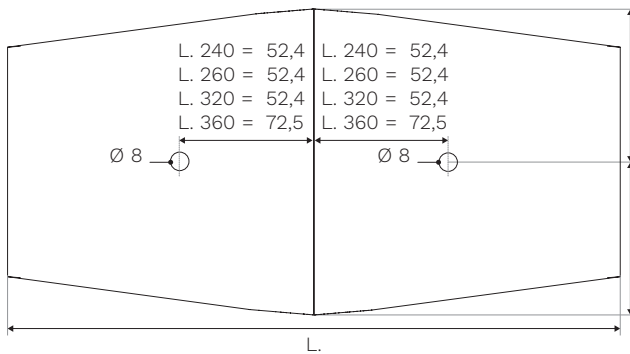
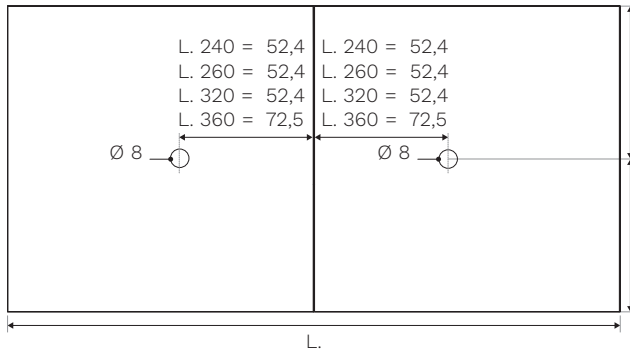

cod. EEFM19

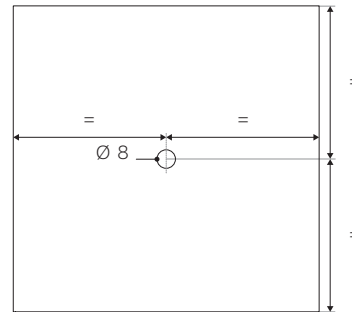

Posizioni VERSATURN 3.0 per tavoli riunione

VERSATURN 3.0 positions for meeting tables

Positions VERSATURN 3.0 pour tables de réunion

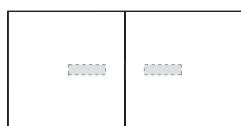

cod. EEFM09 VERSATURN 3.0

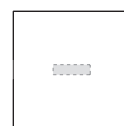
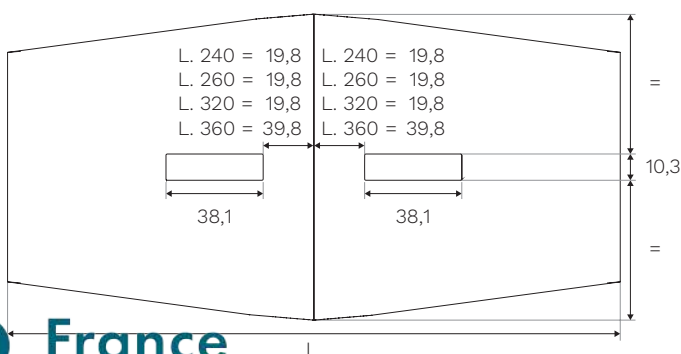
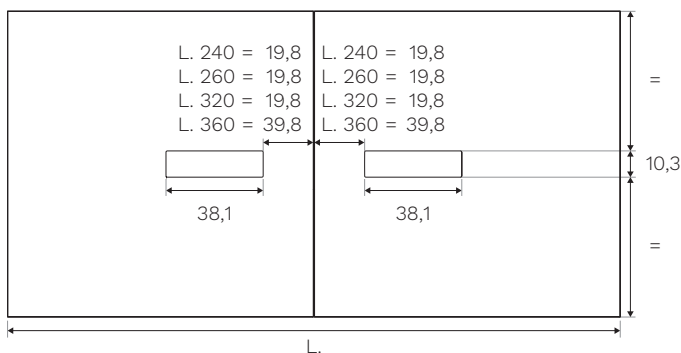

cod. EEFM09 VERSATURN 3.0

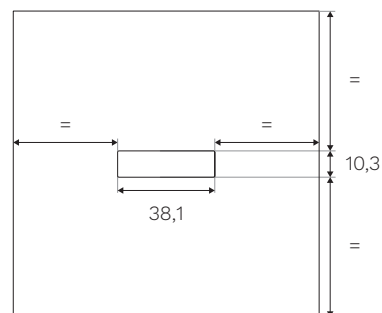
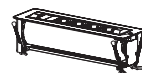

HELORUS

Posizione VERSALIFT per tavoli riunione a botte P. 160 cm

VERSALIFT position for D. 63" barrel-shaped meeting table

Position du VERSALIFT pour tables de réunion en forme de tonneau P. 160 cm

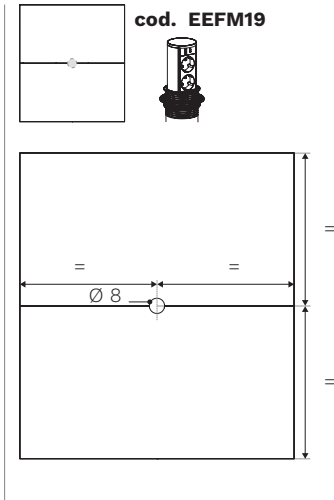
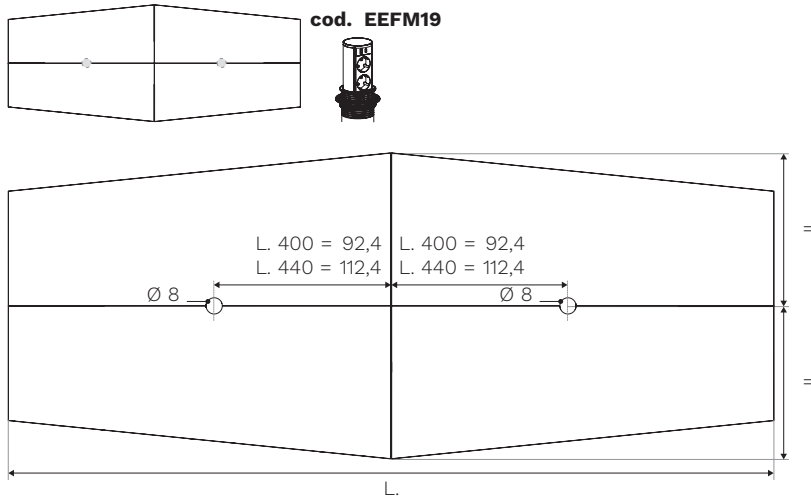

Posizioni VERSATURN 3.0 per tavoli riunione a botte P. 160 cm

VERSATURN 3.0 positions for D. 63" barrel-shaped meeting table

Positions VERSATURN 3.0 pour tables de réunion en forme de tonneau P. 160 cm

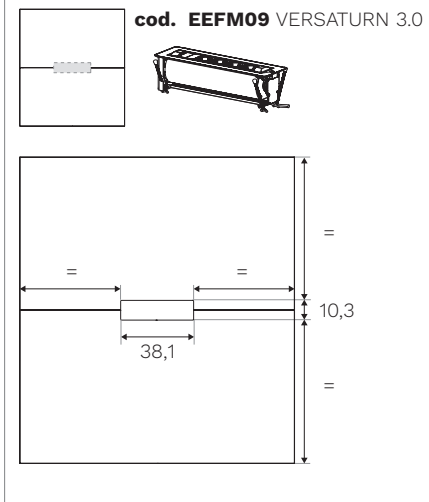
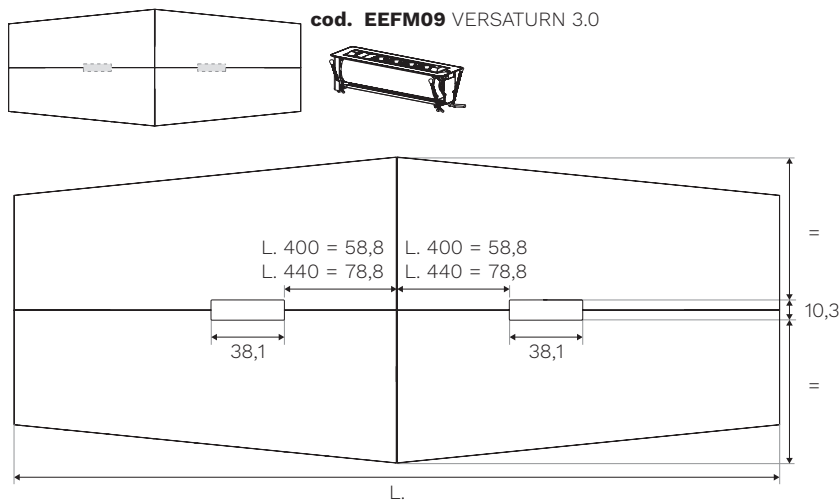

HELORUS

Posizione VERSALIFT per tavoli riunione

VERSALIFT position for meeting tables

Position du VERSALIFT pour tables de réunion

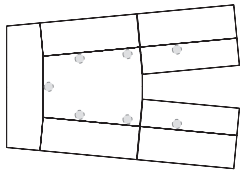

cod. EEFM19

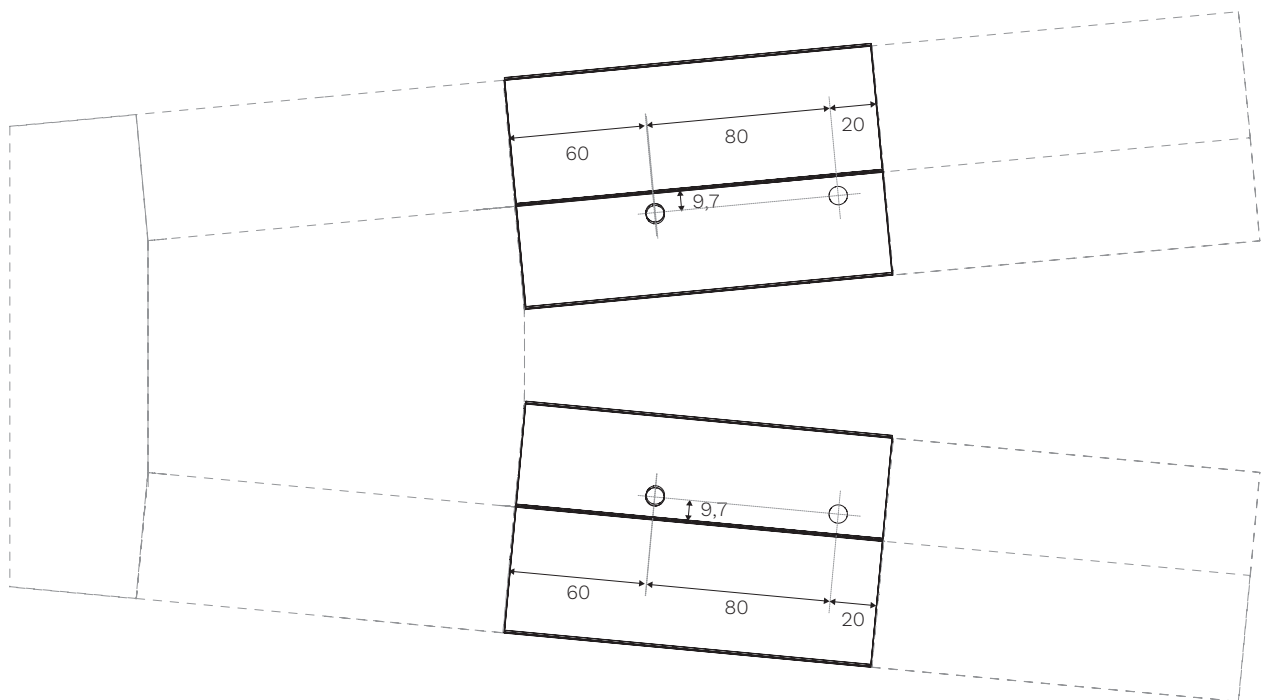
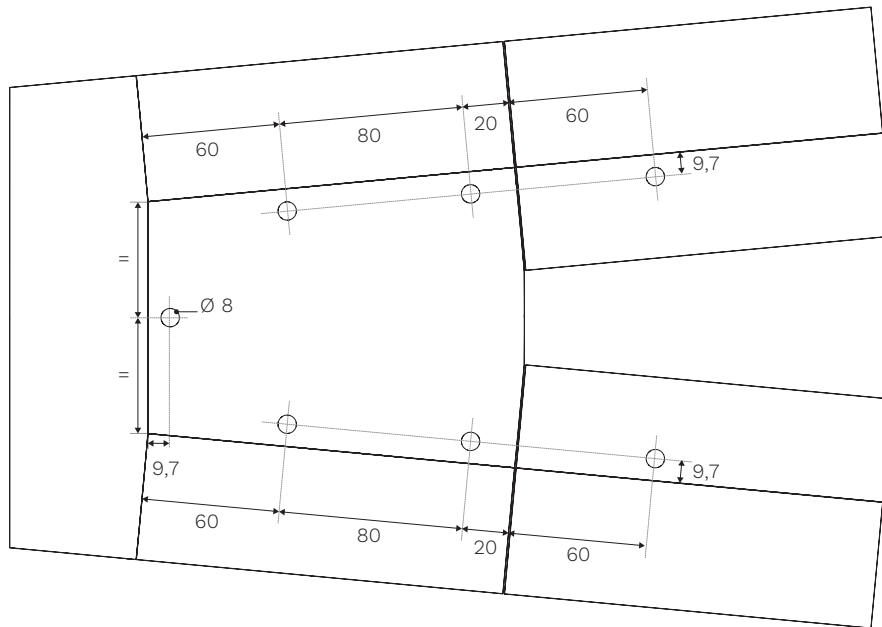

HELORUS

Costruzione codice

How to complete the code
Construction du code

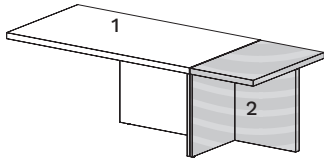

Codice articolo
Item code
Code article

(2) Finitura console
Console finish
Version console

MU0726D + FENE + OMNE

(1) Finitura scrivania
Finish for desk
Version bureau

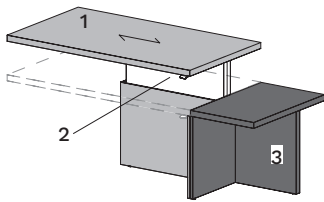

Codice articolo
Item code
Code article

(2) Finitura carter
Carter finish
Version carter

MU1726D + WNS + ZCH + Cat. P + URBC +

(1) Finitura scrivania
Finish for desk
Version bureau

(3) Finitura console
Console finish
Version console



Tipo di spina
Type of plug
Type de prise

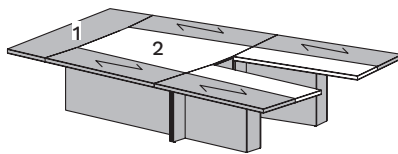

Codice articolo
Item code
Code article

(2) Finitura inserto
Insert finish
Version insert

(2) Finitura Versalift
Versalift finish
Version Versalift

MU3638 + WBI + FEBI + (7X) APP + (7X) EEFM19A02 + BI

(1) Finitura tavolo conferenza
Finish for conference table
Version table conference

(3) Codice VERSALIFT (spina DE)
VERSALIFT code (DE plug)
Code VERSALIFT (prise DE)

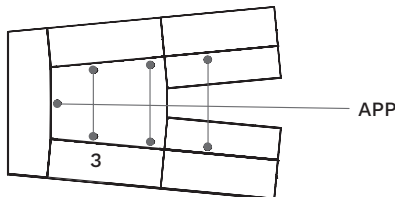

HELORUS

Scrivania con consolle - Scrivania in Fenix e consolle in Oleomalta (F + OM)

Desk with console - Fenix desk and Oleomalta console (F + OM)

Bureau avec console - Bureau en Fenix et console en Oleomalta (F + OM)

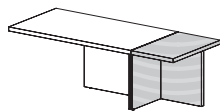

F + OM

Dx
Rh

	L. W.	P. D.	H. H.	COD.		kg lb	m ³ ft ³
Dx Rh	223 87 ³ / ₄	100 39 ³ / ₈	75 29 ¹ / ₂	MU0722D		227,10 501.00	0,380 13.40
	243 95 ⁵ / ₈	100 39 ³ / ₈	75 29 ¹ / ₂	MU0724D		254,20 560.00	0,417 14.70
	263 103 ¹ / ₂	100 39 ³ / ₈	75 29 ¹ / ₂	MU0726D		278,60 614.00	0,459 16.20
	283 111 ³ / ₈	100 39 ³ / ₈	75 29 ¹ / ₂	MU0728D		298,30 658.00	0,497 17.60
Sx Lh	223 87 ³ / ₄	100 39 ³ / ₈	75 29 ¹ / ₂	MU0722S		227,10 501.00	0,380 13.40
	243 95 ⁵ / ₈	100 39 ³ / ₈	75 29 ¹ / ₂	MU0724S		254,20 560.00	0,417 14.70
	263 103 ¹ / ₂	100 39 ³ / ₈	75 29 ¹ / ₂	MU0726S		278,60 614.00	0,459 16.20
	283 111 ³ / ₈	100 39 ³ / ₈	75 29 ¹ / ₂	MU0728S		298,30 658.00	0,497 17.60

Scrivania con consolle - Scrivania in Fenix e consolle in quarzo (F + QU)

Desk with console - Fenix desk and quartz console (F + QU)

Bureau avec console - Bureau en Fenix et console en quartz (F + QU)

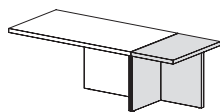

F + QU

Dx
Rh

	L. W.	P. D.	H. H.	COD.		kg lb	m ³ ft ³
Dx Rh	223 87 ³ / ₄	100 39 ³ / ₈	75 29 ¹ / ₂	MU0722D		292,73 645.00	0,407 14.40
	243 95 ⁵ / ₈	100 39 ³ / ₈	75 29 ¹ / ₂	MU0724D		319,82 705.00	0,444 15.70
	263 103 ¹ / ₂	100 39 ³ / ₈	75 29 ¹ / ₂	MU0726D		344,28 759.00	0,486 17.20
	283 111 ³ / ₈	100 39 ³ / ₈	75 29 ¹ / ₂	MU0728D		363,96 802.00	0,524 18.50
Sx Lh	223 87 ³ / ₄	100 39 ³ / ₈	75 29 ¹ / ₂	MU0722S		292,73 645.00	0,407 14.40
	243 95 ⁵ / ₈	100 39 ³ / ₈	75 29 ¹ / ₂	MU0724S		319,82 705.00	0,444 15.70
	263 103 ¹ / ₂	100 39 ³ / ₈	75 29 ¹ / ₂	MU0726S		344,28 759.00	0,486 17.20
	283 111 ³ / ₈	100 39 ³ / ₈	75 29 ¹ / ₂	MU0728S		363,96 802.00	0,524 18.50

Maggiorazioni - Supplement - Supplément			
Foratura per piano per 1 VERSALIFT (non incluso) Drilling for top for 1 VERSALIFT (not included) Perçage pour plateau pour 1 VERSALIFT (pas inclus)	APP		

APP = Posizione VERSALIFT per scrivania

VERSALIFT position for desk

Position du VERSALIFT pour bureau

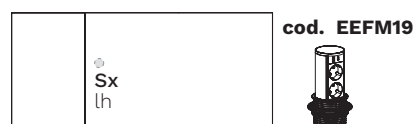
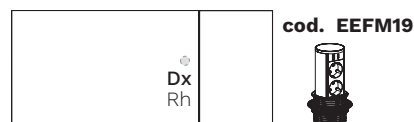

HELORUS

Scrivania con consolle - Scrivania in Fenix e consolle rivestita in pelle (F + Cat. P)

Desk with console - Fenix desk and leather upholstered console (F + Cat. P)

Bureau avec console - Bureau en Fenix et console revêtu en cuir (F + Cat. P)

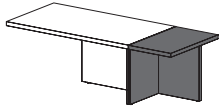

F + Cat. P

Dx
Rh

	L. W.	P. D.	H. H.	COD.		kg lb	m ³ ft ³
Dx Rh	223 87 ³ / ₄	100 39 ³ / ₈	75 29 ¹ / ₂	MU0722D		227,44 501.00	0,379 13.40
	243 95 ⁵ / ₈	100 39 ³ / ₈	75 29 ¹ / ₂	MU0724D		254,53 561.00	0,416 14.70
	263 103 ¹ / ₂	100 39 ³ / ₈	75 29 ¹ / ₂	MU0726D		278,98 615.00	0,458 16.20
	283 111 ³ / ₈	100 39 ³ / ₈	75 29 ¹ / ₂	MU0728D		298,67 658.00	0,496 17.50
Sx Lh	223 87 ³ / ₄	100 39 ³ / ₈	75 29 ¹ / ₂	MU0722S		227,44 501.00	0,379 13.40
	243 95 ⁵ / ₈	100 39 ³ / ₈	75 29 ¹ / ₂	MU0724S		254,53 561.00	0,416 14.70
	263 103 ¹ / ₂	100 39 ³ / ₈	75 29 ¹ / ₂	MU0726S		278,98 615.00	0,458 16.20
	283 111 ³ / ₈	100 39 ³ / ₈	75 29 ¹ / ₂	MU0728S		298,67 658.00	0,496 17.50

Maggiorazioni - Supplement - Supplément

Foratura per piano per 1 VERSALIFT (non incluso)
Drilling for top for 1 VERSALIFT (not included)
Perçage pour plateau pour 1 VERSALIFT (pas inclus)

APP

APP = Posizione VERSALIFT per scrivania
VERSALIFT position for desk
Position du VERSALIFT pour bureau

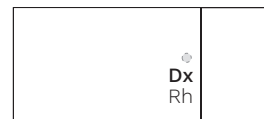

cod. EEFM19

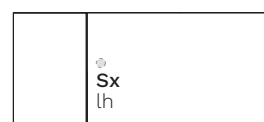

cod. EEFM19



HELORUS

Scrivania con consolle - Scrivania in legno e consolle in Fenix (W + F)

Desk with console - Veneer desk and Fenix console (W + F)

Bureau avec console - Bureau en bois et console en Fenix (W + F)

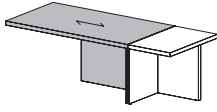

W + F

Dx
Rh

	L. W.	P. D.	H. H.	COD.		kg lb	m ³ ft ³
Dx Rh	223 87 ³ / ₄	100 39 ³ / ₈	75 29 ¹ / ₂	MU0722D		229,28 505.00	0,380 13.40
	243 95 ⁵ / ₈	100 39 ³ / ₈	75 29 ¹ / ₂	MU0724D		256,11 565.00	0,417 14.70
	263 103 ¹ / ₂	100 39 ³ / ₈	75 29 ¹ / ₂	MU0726D		280,82 619.00	0,459 16.20
	283 111 ³ / ₈	100 39 ³ / ₈	75 29 ¹ / ₂	MU0728D		300,75 663.00	0,497 17.60
Sx Lh	223 87 ³ / ₄	100 39 ³ / ₈	75 29 ¹ / ₂	MU0722S		229,28 505.00	0,380 13.40
	243 95 ⁵ / ₈	100 39 ³ / ₈	75 29 ¹ / ₂	MU0724S		256,11 565.00	0,417 14.70
	263 103 ¹ / ₂	100 39 ³ / ₈	75 29 ¹ / ₂	MU0726S		280,82 619.00	0,459 16.20
	283 111 ³ / ₈	100 39 ³ / ₈	75 29 ¹ / ₂	MU0728S		300,75 663.00	0,497 17.60

Scrivania con consolle - Scrivania in legno e consolle in Oleomalta (W + OM)

Desk with console - Veneer desk and Oleomalta console (W + OM)

Bureau avec console - Bureau en bois et console en Oleomalta (W + OM)

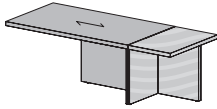

W + OM

Dx
Rh

	L. W.	P. D.	H. H.	COD.		kg lb	m ³ ft ³
Dx Rh	223 87 ³ / ₄	100 39 ³ / ₈	75 29 ¹ / ₂	MU0722D		228,08 503.00	0,380 13.40
	243 95 ⁵ / ₈	100 39 ³ / ₈	75 29 ¹ / ₂	MU0724D		254,92 562.00	0,417 14.70
	263 103 ¹ / ₂	100 39 ³ / ₈	75 29 ¹ / ₂	MU0726D		279,62 616.00	0,459 16.20
	283 111 ³ / ₈	100 39 ³ / ₈	75 29 ¹ / ₂	MU0728D		299,55 660.00	0,497 17.60
Sx Lh	223 87 ³ / ₄	100 39 ³ / ₈	75 29 ¹ / ₂	MU0722S		228,08 503.00	0,380 13.40
	243 95 ⁵ / ₈	100 39 ³ / ₈	75 29 ¹ / ₂	MU0724S		254,92 562.00	0,417 14.70
	263 103 ¹ / ₂	100 39 ³ / ₈	75 29 ¹ / ₂	MU0726S		279,62 616.00	0,459 16.20
	283 111 ³ / ₈	100 39 ³ / ₈	75 29 ¹ / ₂	MU0728S		299,55 660.00	0,497 17.60

Maggiorazioni - Supplement - Supplément			
Foratura per piano per 1 VERSALIFT (non incluso) Drilling for top for 1 VERSALIFT (not included) Perçage pour plateau pour 1 VERSALIFT (pas inclus)	APP		

APP = Posizione VERSALIFT per scrivania

VERSALIFT position for desk

Position du VERSALIFT pour bureau

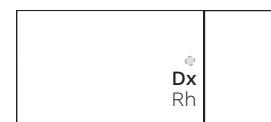

cod. EEFM19

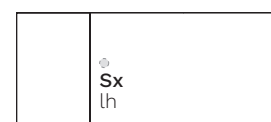

cod. EEFM19



HELORUS

Scrivania con consolle - Scrivania in legno e consolle in quarzo (W + QU)

Desk with console - Veneer desk and quartz console (W + QU)

Bureau avec console - Bureau en bois et console en quartz (W + QU)

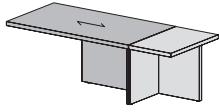

W + QU

Dx
Rh

	L. W.	P. D.	H. H.	COD.		kg lb	m ³ ft ³
Dx Rh	223 87"3/4	100 39"3/8	75 29"1/2	MU0722D		293,73 648.00	0,407 14.40
	243 95"5/8	100 39"3/8	75 29"1/2	MU0724D		320,56 707.00	0,444 15.70
	263 103"1/2	100 39"3/8	75 29"1/2	MU0726D		345,27 761.00	0,486 17.20
	283 111"3/8	100 39"3/8	75 29"1/2	MU0728D		365,20 805.00	0,524 18.50
Sx Lh	223 87"3/4	100 39"3/8	75 29"1/2	MU0722S		293,73 648.00	0,407 14.40
	243 95"5/8	100 39"3/8	75 29"1/2	MU0724S		320,56 707.00	0,444 15.70
	263 103"1/2	100 39"3/8	75 29"1/2	MU0726S		345,27 761.00	0,486 17.20
	283 111"3/8	100 39"3/8	75 29"1/2	MU0728S		365,20 805.00	0,524 18.50

Scrivania con consolle - Scrivania in legno e consolle rivestita in pelle (W + Cat. P)

Desk with console - Veneer desk and leather upholstered console (W + Cat. P)

Bureau avec console - Bureau en bois et console revêtu en cuir (W + Cat. P)

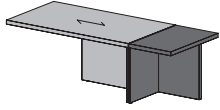

W + Cat. P

Dx
Rh

	L. W.	P. D.	H. H.	COD.		kg lb	m ³ ft ³
Dx Rh	223 87"3/4	100 39"3/8	75 29"1/2	MU0722D		228,58 504.00	0,381 13.50
	243 95"5/8	100 39"3/8	75 29"1/2	MU0724D		255,41 563.00	0,418 14.80
	263 103"1/2	100 39"3/8	75 29"1/2	MU0726D		280,11 618.00	0,460 16.20
	283 111"3/8	100 39"3/8	75 29"1/2	MU0728D		300,05 661.00	0,498 17.60
Sx Lh	223 87"3/4	100 39"3/8	75 29"1/2	MU0722S		228,58 504.00	0,381 13.50
	243 95"5/8	100 39"3/8	75 29"1/2	MU0724S		255,41 563.00	0,418 14.80
	263 103"1/2	100 39"3/8	75 29"1/2	MU0726S		280,11 618.00	0,460 16.20
	283 111"3/8	100 39"3/8	75 29"1/2	MU0728S		300,05 661.00	0,498 17.60

Maggiorazioni - Supplement - Supplément

Foratura per piano per 1 VERSALIFT (non incluso)
Drilling for top for 1 VERSALIFT (not included)
Perçage pour plateau pour 1 VERSALIFT (pas inclus)

APP

APP = Posizione VERSALIFT per scrivania
VERSALIFT position for desk
Position du VERSALIFT pour bureau

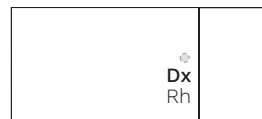

cod. EEFM19

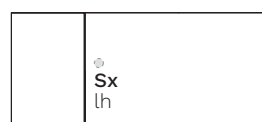

cod. EEFM19



HELORUS

Scrivania elevabile in altezza - Scrivania in Fenix e consolle in Oleomalta (F + OM) - Carter in metallo: champagne (ZCH), piombo satinato (ZPS) - Si prega di specificare il tipo di spina (Schuko-UK-US)

Height-adjustable desk - Fenix desk and Oleomalta console (F + OM) - Metal carter: champagne (ZCH), satin lead (ZPS) - Please specify the type of plug (Schuko-UK-US)

Bureau réglable en hauteur - Bureau en Fenix et console en Oleomalta (F + OM) - Carter en métal: champagne (ZCH), gris plomb satiné (ZPS) - Veuillez spécifier le type de prise (Schuko-UK-US)

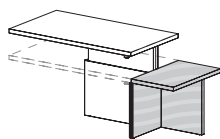

F + OM

Dx
Rh

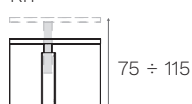

	L. W.	P. D.	H. H.	COD.		kg lb	m ³ ft ³
Dx Rh	243 95*5/8	100 39*3/8	75÷115 29*1/2÷45*1/4	MU1724D ZCH - ZPS		273,11 602.00	0,435 15.40
	263 103*1/2	100 39*3/8	75÷115 29*1/2÷45*1/4	MU1726D ZCH - ZPS		293,39 647.00	0,467 16.50
Sx Lh	243 95*5/8	100 39*3/8	75÷115 29*1/2÷45*1/4	MU1724S ZCH - ZPS		273,11 602.00	0,435 15.40
	263 103*1/2	100 39*3/8	75÷115 29*1/2÷45*1/4	MU1726S ZCH - ZPS		293,39 647.00	0,467 16.50

Scrivania elevabile in altezza - Scrivania in Fenix e consolle in quarzo (F + QU) - Carter in metallo: champagne (ZCH), piombo satinato (ZPS) - Si prega di specificare il tipo di spina (Schuko-UK-US)

Height-adjustable desk - Fenix desk and quartz console (F + QU) - Metal carter: champagne (ZCH), satin lead (ZPS) - Please specify the type of plug (Schuko-UK-US)

Bureau réglable en hauteur - Bureau en Fenix et console en quartz (F + QU) - Carter en métal: champagne (ZCH), gris plomb satiné (ZPS) - Veuillez spécifier le type de prise (Schuko-UK-US)

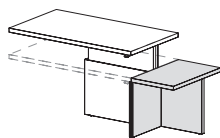

F + QU

Dx
Rh

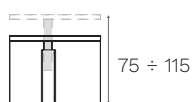

	L. W.	P. D.	H. H.	COD.		kg lb	m ³ ft ³
Dx Rh	243 95*5/8	100 39*3/8	75÷115 29*1/2÷45*1/4	MU1724D ZCH - ZPS		338,76 747.00	0,462 16.30
	263 103*1/2	100 39*3/8	75÷115 29*1/2÷45*1/4	MU1726D ZCH - ZPS		359,03 792.00	0,494 17.40
Sx Lh	243 95*5/8	100 39*3/8	75÷115 29*1/2÷45*1/4	MU1724S ZCH - ZPS		338,76 747.00	0,462 16.30
	263 103*1/2	100 39*3/8	75÷115 29*1/2÷45*1/4	MU1726S ZCH - ZPS		359,03 792.00	0,494 17.40

Scrivania elevabile in altezza - Scrivania in Fenix e consolle rivestita in pelle (F + Cat. P) - Carter in metallo: champagne (ZCH), piombo satinato (ZPS) - Si prega di specificare il tipo di spina (Schuko-UK-US)

Height-adjustable desk - Fenix desk and leather upholstered console (F + Cat. P) - Metal carter: champagne (ZCH), satin lead (ZPS) - Please specify the type of plug (Schuko-UK-US)

Bureau réglable en hauteur - Bureau en Fenix et console revêtu en cuir (F + Cat. P) - Carter en métal: champagne (ZCH), gris plomb satiné (ZPS) - Veuillez spécifier le type de prise (Schuko-UK-US)

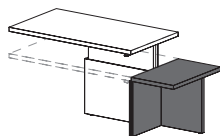

F + Cat. P

Dx
Rh

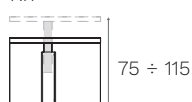

	L. W.	P. D.	H. H.	COD.		kg lb	m ³ ft ³
Dx Rh	243 95*5/8	100 39*3/8	75÷115 29*1/2÷45*1/4	MU1724D ZCH - ZPS		273,60 603.00	0,436 15.40
	263 103*1/2	100 39*3/8	75÷115 29*1/2÷45*1/4	MU1726D ZCH - ZPS		293,88 648.00	0,468 16.50
Sx Lh	243 95*5/8	100 39*3/8	75÷115 29*1/2÷45*1/4	MU1724S ZCH - ZPS		273,60 603.00	0,436 15.40
	263 103*1/2	100 39*3/8	75÷115 29*1/2÷45*1/4	MU1726S ZCH - ZPS		293,88 648.00	0,468 16.50

Maggiorazioni - Supplement - Supplément

Foratura per piano per 1 VERSALIFT (non incluso)
Drilling for top for 1 VERSALIFT (not included)
Perçage pour plateau pour 1 VERSALIFT (pas inclus)

APP

HELORUS

Scrivania elevabile in altezza - Scrivania in legno e consolle in Fenix (W + F) - Carter in metallo: champagne (ZCH), piombo satinato (ZPS) - Si prega di specificare il tipo di spina (Schuko-UK-US)

Height-adjustable desk - Veneer desk and Fenix console (W + F) - Metal carter: champagne (ZCH), satin lead (ZPS) - Please specify the type of plug (Schuko-UK-US)

Bureau réglable en hauteur - Bureau en bois et console en Fenix (W + F) - Carter en métal: champagne (ZCH), gris plomb satiné (ZPS) - Veuillez spécifier le type de prise (Schuko-UK-US)

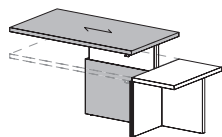

W + F

Dx

Rh

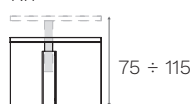

	L. W.	P. D.	H. H.	COD.		kg lb	m ³ ft ³
Dx Rh	243 95 ⁵ / ₈	100 39 ³ / ₈	75÷115 29 ¹ / ₂ ÷45 ¹ / ₄	MU1724D ZCH - ZPS		275,08 606.00	0,435 15.40
	263 103 ¹ / ₂	100 39 ³ / ₈	75÷115 29 ¹ / ₂ ÷45 ¹ / ₄	MU1726D ZCH - ZPS		295,61 652.00	0,467 16.50
Sx Lh	243 95 ⁵ / ₈	100 39 ³ / ₈	75÷115 29 ¹ / ₂ ÷45 ¹ / ₄	MU1724S ZCH - ZPS		275,08 606.00	0,435 15.40
	263 103 ¹ / ₂	100 39 ³ / ₈	75÷115 29 ¹ / ₂ ÷45 ¹ / ₄	MU1726S ZCH - ZPS		295,61 652.00	0,467 16.50

Scrivania elevabile in altezza - Scrivania in legno e consolle in Oleomalta (W + OM) - Carter in metallo: champagne (ZCH), piombo satinato (ZPS) - Si prega di specificare il tipo di spina (Schuko-UK-US)

Height-adjustable desk - Veneer desk and Oleomalta console (W + OM) - Metal carter: champagne (ZCH), satin lead (ZPS) - Please specify the type of plug (Schuko-UK-US)

Bureau réglable en hauteur - Bureau en bois et console en Oleomalta (W + OM) - Carter en métal: champagne (ZCH), gris plomb satiné (ZPS) - Veuillez spécifier le type de prise (Schuko-UK-US)

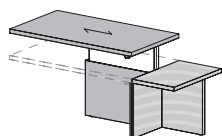

W + OM

Dx

Rh

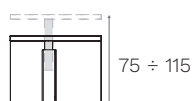

	L. W.	P. D.	H. H.	COD.		kg lb	m ³ ft ³
Dx Rh	243 95 ⁵ / ₈	100 39 ³ / ₈	75÷115 29 ¹ / ₂ ÷45 ¹ / ₄	MU1724D ZCH - ZPS		273,89 604.00	0,435 15.40
	263 103 ¹ / ₂	100 39 ³ / ₈	75÷115 29 ¹ / ₂ ÷45 ¹ / ₄	MU1726D ZCH - ZPS		294,41 649.00	0,467 16.50
Sx Lh	243 95 ⁵ / ₈	100 39 ³ / ₈	75÷115 29 ¹ / ₂ ÷45 ¹ / ₄	MU1724S ZCH - ZPS		273,89 604.00	0,435 15.40
	263 103 ¹ / ₂	100 39 ³ / ₈	75÷115 29 ¹ / ₂ ÷45 ¹ / ₄	MU1726S ZCH - ZPS		294,41 649.00	0,467 16.50

Maggiorazioni - Supplement - Supplément

Foratura per piano per 1 VERSALIFT (non incluso)

Drilling for top for 1 VERSALIFT (not included)

Perçage pour plateau pour 1 VERSALIFT (pas inclus)

APP

APP = Posizione VERSALIFT per scrivania

VERSALIFT position for desk

Position du VERSALIFT pour bureau

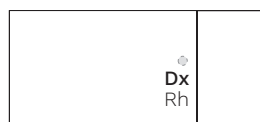

cod. EEFM19

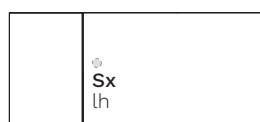

cod. EEFM19



HELORUS

Scrivania elevabile in altezza - Scrivania in legno e consolle in quarzo (W + QU) - Carter in metallo: champagne (ZCH), piombo satinato (ZPS) - Si prega di specificare il tipo di spina (Schuko-UK-US)

Height-adjustable desk - Veneer desk and quartz console (W + QU) - Metal carter: champagne (ZCH), satin lead (ZPS) - Please specify the type of plug (Schuko-UK-US)

Bureau réglable en hauteur - Bureau en bois et console en quartz (W + QU) - Carter en métal: champagne (ZCH), gris plomb satiné (ZPS) - Veuillez spécifier le type de prise (Schuko-UK-US)

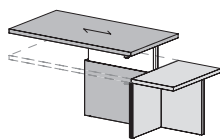

W + QU

Dx
Rh

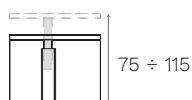

	L. W.	P. D.	H. H.	COD.		kg lb	m ³ ft ³
Dx Rh	243 95*5/8	100 39*3/8	75÷115 29*1/2÷45*1/4	MU1724D ZCH - ZPS		339,53 749.00	0,462 16.30
	263 103*1/2	100 39*3/8	75÷115 29*1/2÷45*1/4	MU1726D ZCH - ZPS		360,06 794.00	0,494 17.40
Sx Lh	243 95*5/8	100 39*3/8	75÷115 29*1/2÷45*1/4	MU1724S ZCH - ZPS		339,53 749.00	0,462 16.30
	263 103*1/2	100 39*3/8	75÷115 29*1/2÷45*1/4	MU1726S ZCH - ZPS		360,06 794.00	0,494 17.40

Scrivania elevabile in altezza - Scrivania in legno e consolle rivestita in pelle (W + Cat. P) - Carter in metallo: champagne (ZCH), piombo satinato (ZPS) - Si prega di specificare il tipo di spina (Schuko-UK-US)

Height-adjustable desk - Veneer desk and leather upholstered console (W + Cat. P) - Metal carter: champagne (ZCH), satin lead (ZPS) - Please specify the type of plug (EU-UK-US)

Bureau réglable en hauteur - Bureau en bois et console revêtu en cuir (W + Cat. P) - Carter en métal: champagne (ZCH), gris plomb satiné (ZPS) - Veuillez spécifier le type de prise (Schuko-UK-US)

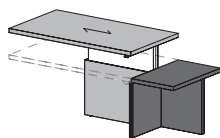

W + Cat. P

Dx
Rh

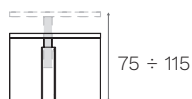

	L. W.	P. D.	H. H.	COD.		kg lb	m ³ ft ³
Dx Rh	243 95*5/8	100 39*3/8	75÷115 29*1/2÷45*1/4	MU1724D ZCH - ZPS		274,38 605.00	0,436 15.40
	263 103*1/2	100 39*3/8	75÷115 29*1/2÷45*1/4	MU1726D ZCH - ZPS		294,90 650.00	0,468 16.50
Sx Lh	243 95*5/8	100 39*3/8	75÷115 29*1/2÷45*1/4	MU1724S ZCH - ZPS		274,38 605.00	0,436 15.40
	263 103*1/2	100 39*3/8	75÷115 29*1/2÷45*1/4	MU1726S ZCH - ZPS		294,90 650.00	0,468 16.50

Maggiorazioni - Supplement - Supplément			
Foratura per piano per 1 VERSALIFT (non incluso) Drilling for top for 1 VERSALIFT (not included) Perçage pour plateau pour 1 VERSALIFT (pas inclus)	APP		

APP = Posizione VERSALIFT per scrivania
VERSALIFT position for desk
Position du VERSALIFT pour bureau

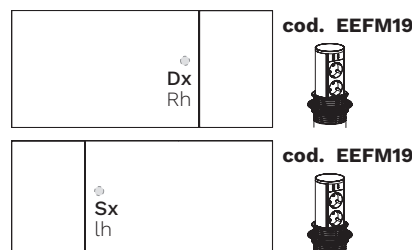

HELORUS

Cassettiera su ruote con 4 cassetti: Fenix (F), Hpl (HL), laccato opaco (LA), Oleomalta (OM) - Apertura Push-pull (inclusa) - 5 ruote piroettanti senza freno

Pedestal on castors with 4 drawers: Fenix (F), Hpl (HL), matt lacquered (LA), Oleomalta (OM) - Push-pull opening (included) - 5 swivel castors without brake

Caisson sur roulettes avec 4 tiroirs: Fenix (F), Hpl (HL), laqué mat (LA), Oleomalta (OM) - Ouverture Push-pull (inclus) - 5 roulettes pivotantes sans frein



5 ruote piroettanti
5 swivel castors
5 roulettes pivotantes



Non è prevista la serratura
There is no lock
La serrure n'est pas prévue



L. W.	P. D.	H. H.	COD.	kg lb	m ³ ft ³
59 23 ¹¹ / ₄	59 23 ¹¹ / ₄	70 27 ¹¹ / ₂	MU0809	55,23 122.00	0,271 9.58

Cassettiera appesa con 3 cassetti: Fenix (F), Hpl (HL), laccato opaco (LA), Oleomalta (OM) - Apertura Push-pull (inclusa)

Hanging pedestals with 3 drawers: Fenix (F), Hpl (HL), matt lacquered (LA), Oleomalta (OM) - Push-pull opening (included)

Caisson suspendu avec 3 tiroirs: Fenix (F), Hpl (HL), laqué mat (LA), Oleomalta (OM) - Ouverture Push-pull (inclus)

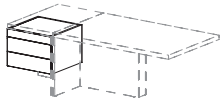

Non è prevista la serratura
There is no lock
La serrure n'est pas prévue



L. W.	P. D.	H. H.	COD.	kg lb	m ³ ft ³
60 23 ⁵ / ₈	59 23 ¹¹ / ₄	43 16 ⁷ / ₈	MU0801	40,72 89.80	0,171 6.02

HELORUS

Mobile di servizio con 4 ante - Mobile di servizio: Fenix (F), Hpl (HL), laccato opaco (LA), Oleomalta (OM) - Apertura Push-pull (inclusa)
 Service unit with 4 doors - Service unit: Fenix (F), Hpl (HL), matt lacquered (LA), Oleomalta (OM) - Push-pull opening (included)
 Meuble de service avec 4 portes - Meuble de service: Fenix (F), Hpl (HL), laqué mat (LA), Oleomalta (OM) - Ouverture Push-pull (inclus)

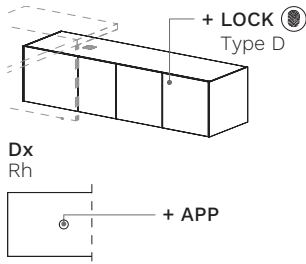

	L. W.	P. D.	H. H.	COD.		kg lb	m ³ ft ³
Dx Rh	202 79 ¹ / ₂	59 23 ¹ / ₄	52 20 ¹ / ₂	MU0901D		101,75 224.00	0,777 27.40
Sx Lh	202 79 ¹ / ₂	59 23 ¹ / ₄	52 20 ¹ / ₂	MU0901S		101,75 224.00	0,777 27.40

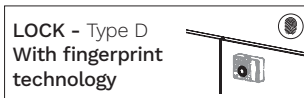

Maggiorazioni - Supplement - Supplément			
Foratura top mobile per 1 VERSALIFT (non incluso) Drilling for top for 1 VERSALIFT (not included) Perçage pour dessus pour 1 VERSALIFT (pas inclus)	APP		
Serratura con tecnologia a impronta digitale Lock with fingerprint technology Serrure à empreinte digitale	LOCK Type D		

Mobile di servizio con 2 ante e 1 cassettiera a 3 cassetti - Mobile di servizio: Fenix (F), Hpl (HL), laccato opaco (LA), Oleomalta (OM) - Apertura Push-pull (inclusa)
 Service unit with 2 doors and 1 pedestal with 3 drawers - Service unit: Fenix (F), Hpl (HL), matt lacquered (LA), Oleomalta (OM) - Push-pull opening (included)
 Meuble de service avec 2 portes et 1 caisson avec 3 tiroirs - Meuble de service: Fenix (F), Hpl (HL), laqué mat (LA), Oleomalta (OM) - Ouverture Push-pull (inclus)

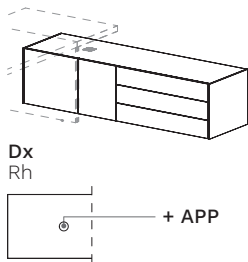

	L. W.	P. D.	H. H.	COD.		kg lb	m ³ ft ³
Dx Rh	202 79 ¹ / ₂	59 23 ¹ / ₄	52 20 ¹ / ₂	MU0902D		115,42 254.00	0,777 27.40
Sx Lh	202 79 ¹ / ₂	59 23 ¹ / ₄	52 20 ¹ / ₂	MU0902S		115,42 254.00	0,777 27.40

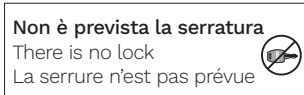

Maggiorazioni - Supplement - Supplément			
Foratura top mobile per 1 VERSALIFT (non incluso) Drilling for top for 1 VERSALIFT (not included) Perçage pour dessus pour 1 VERSALIFT (pas inclus)	APP		

HELORUS

Mobile di servizio con 2 ante, 1 cassettera a 3 cassetti e 1 vano con frigo - Mobile di servizio: Fenix (F), Hpl (HL), laccato opaco (LA), Oleomalta (OM) - Apertura Push-pull (inclusa) - Si prega di specificare voltaggio (220-230V/115V)

Service unit with 2 doors, 1 pedestal with 3 drawers and 1 unit with fridge - Service unit: Fenix (F), Hpl (HL), matt lacquered (LA), Oleomalta (OM) - Push-pull opening (included) - Please specify voltage (220-230V/115V)

Meuble de service avec 2 portes, 1 caisson avec 3 tiroirs et 1 niche avec réfrigérateur - Meuble de service: Fenix (F), Hpl (HL), laqué mat (LA), Oleomalta (OM) - Ouverture Push-pull (inclus) - Veuillez préciser le voltage (220-230V/115V)

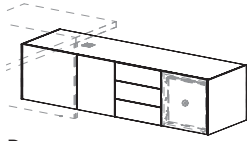

Dx
Rh



	L. W.	P. D.	H. H.	COD.			kg lb	m ³ ft ³
Dx Rh	202 79 ¹ / ₂	59 23 ¹ / ₄	52 20 ¹ / ₂	MU0904D			174,47 385.00	0,828 29.20
Sx Lh	202 79 ¹ / ₂	59 23 ¹ / ₄	52 20 ¹ / ₂	MU0904S			174,47 385.00	0,828 29.20

Non è prevista la serratura

There is no lock

La serrure n'est pas prévue



Maggiorazioni - Supplement - Supplément

Foratura top mobile per 1 VERSALIFT (non incluso)

Drilling for top for 1 VERSALIFT (not included)

Perçage pour dessus pour 1 VERSALIFT (pas inclus)

APP

Fioriera (non a tenuta stagna): Fenix (F), Hpl (HL), laccato opaco (LA), Oleomalta (OM)

Plant box (not leakproof): Fenix (F), Hpl (HL), matt lacquered (LA), Oleomalta (OM)

Bac à fleur (non étanche): Fenix (F), Hpl (HL), laqué mat (LA), Oleomalta (OM)

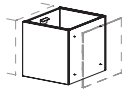

L. W.	P. D.	H. H.	COD.	kg lb	m ³ ft ³
50 19 ⁵ / ₈	59 23 ¹ / ₄	52 20 ¹ / ₂	MU20103	40,31 88.90	0,168 5.93

HELORUS

Mobile di servizio con 2 ante e 1 cassetto laterale ad estrazione totale - Mobile di servizio: Fenix (F), Hpl (HL), laccato opaco (LA), Oleomalta (OM) - Apertura Push-pull (inclusa)

Service unit with 2 doors and 1 full-extension side drawer - Service unit: Fenix (F), Hpl (HL), matt lacquered (LA), Oleomalta (OM) - Push-pull opening (included)

Meuble de service avec 2 portes et 1 tiroir latéral à extraction totale - Meuble de service: Fenix (F), Hpl (HL), laqué mat (LA), Oleomalta (OM) - Ouverture Push-pull (inclus)

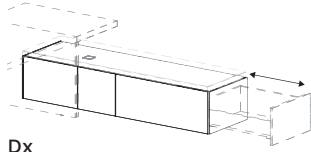

Dx
Rh



	L. W.	P. D.	H. H.	COD.			kg lb	m ³ ft ³
Dx Rh	204 80 ³ / ₈	59 23 ¹ / ₄	40 15 ³ / ₄	MU0903D			102,34 226.00	0,577 20.40
Sx Lh	204 80 ³ / ₈	59 23 ¹ / ₄	40 15 ³ / ₄	MU0903S			102,34 226.00	0,577 20.40

Non è prevista la serratura

There is no lock

La serrure n'est pas prévue



Maggiorazioni - Supplement - Supplément

Foratura top mobile per 1 VERSALIFT (non incluso)

Drilling for top for 1 VERSALIFT (not included)

Perçage pour dessus pour 1 VERSALIFT (pas inclus)

APP

Cuscino per mobile di servizio cod. MU0902D / MU0902S

Cushion for service unit cod. MU0902D / MU0902S

Coussin pour meuble de service cod. MU0902D / MU0902S

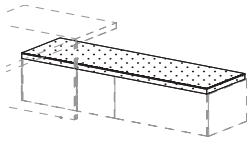

	L. W.	P. D.	H. H.	COD.			kg lb	m ³ ft ³
	203 79 ⁷ / ₈	59 23 ¹ / ₄	5 2"	MUC020			8,50 18.70	0,902 31.90

HELORUS

Mediawall e tavolo trapezoidale in Fenix (F) - Foro Ø 8 cm per uscita cavi (x2) - Staffa VESA per monitor 40" - 65" inclusa (portata max: 60 kg)

Fenix Mediawall and trapezoidal table (F) - Ø 3"1/8 hole for cable outlet (x2) - VESA bracket for 40" - 65" monitor included (max. load capacity: 132.28 lb)

Mediawall et table trapézoïdale en Fenix (F) - Trou de Ø 8 cm pour le passage des câbles (x2) - Support VESA pour moniteur 40" - 65" inclus (poids max. supporté: 60 kg)

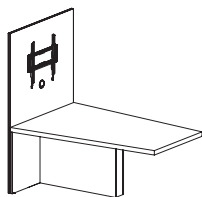

F

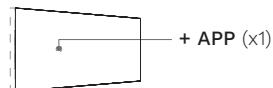

L. W.	P. D.	H. H.	COD.	kg lb	m ³ ft ³
190 74"3/4	120 47"1/4	181 71"1/4	MU3401	217,94 480.00	0,478 16.90

Mediawall in Fenix con tavolo trapezoidale in legno (F + W) - Foro Ø 8 cm per uscita cavi (x2) - Staffa VESA per monitor 40" - 65" inclusa (portata max: 60 kg)

Fenix Mediawall with veneer trapezoidal table (F + W) - Ø 3"1/8 hole for cable outlet (x2) - VESA bracket for 40" - 65" monitor included (max. load capacity: 132.28 lb)

Mediawall en Fenix avec table trapézoïdale en bois (F + W) - Trou de Ø 8 cm pour le passage des câbles (x2) - Support VESA pour moniteur 40" - 65" inclus (poids max. supporté: 60 kg)

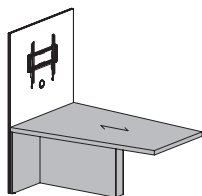

F + W

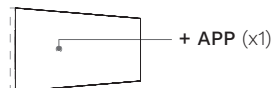

L. W.	P. D.	H. H.	COD.	kg lb	m ³ ft ³
190 74"3/4	120 47"1/4	181 71"1/4	MU3401	218,80 482.00	0,478 16.90

Mediawall e tavolo trapezoidale in legno (W) - Foro Ø 8 cm per uscita cavi (x2) - Staffa VESA per monitor 40" - 65" inclusa (portata max: 60 kg)

Veneer Mediawall and trapezoidal table (W) - Ø 3"1/8 hole for cable outlet (x2) - VESA bracket for 40" - 65" monitor included (max. load capacity: 132.28 lb)

Mediawall et table trapézoïdale en bois (W) - Trou de Ø 8 cm pour le passage des câbles (x2) - Support VESA pour moniteur 40" - 65" inclus (poids max. supporté: 60 kg)

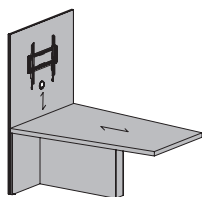

W

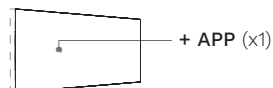

L. W.	P. D.	H. H.	COD.	kg lb	m ³ ft ³
190 74"3/4	120 47"1/4	181 71"1/4	MU3401	217,25 479.00	0,476 16.80

Maggiorazioni - Supplement - Supplément

Foratura per piano per 1 VERSATURN (non incluso)
Drilling for top for 1 VERSATURN (not included)
Perçage pour plateau pour 1 VERSATURN (pas inclus)

APP

Foratura per piano per 1 VERSALIFT (non incluso)
Drilling for top for 1 VERSALIFT (not included)
Perçage pour plateau pour 1 VERSALIFT (pas inclus)

APP

HELORUS

Mediawall in legno con tavolo trapezoidale in Fenix (W + F) - Foro Ø 8 cm per uscita cavi (x2) - Staffa VESA per monitor 40" - 65" inclusa (portata max: 60 kg)

Veneer Mediawall with Fenix trapezoidal table (W + F) - Ø 3"1/8 hole for cable outlet (x2) - VESA bracket for 40" - 65" monitor included (max. load capacity: 132.28 lb)

Mediawall en bois avec table trapézoïdale en Fenix (W + F) - Trou de Ø 8 cm pour le passage des câbles (x2) - Support VESA pour moniteur 40" - 65" inclus (poids max. supporté: 60 kg)

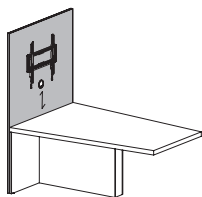

W + F

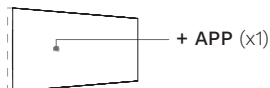

L. W.	P. D.	H. H.	COD.		kg lb	m ³ ft ³
190 74"3/4	120 47"1/4	181 71"1/4	MU3401		216,39 477.00	0,476 16.80

Maggiorazioni - Supplement - Supplément			
Foratura per piano per 1 VERSATURN (non incluso) Drilling for top for 1 VERSATURN (not included) Perçage pour plateau pour 1 VERSATURN (pas inclus)	APP		
Foratura per piano per 1 VERSALIFT (non incluso) Drilling for top for 1 VERSALIFT (not included) Perçage pour plateau pour 1 VERSALIFT (pas inclus)	APP		

HELORUS

Tavolo riunione: Fenix (F), Fenix con inserto centrale rivestito in pelle (F + Cat. P)

Meeting table: Fenix (F), Fenix with leather upholstered central insert (F + Cat. P)

Table réunion: Fenix (F), Fenix avec insert central revêtu en cuir (F + Cat. P)

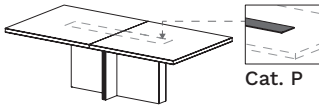
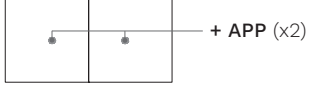
	L. W.	P. D.	H. H.	COD.		kg lb	m ³ ft ³
 Cat. P							
F 8	240 94 ¹ / ₂	120 47 ¹ / ₄	75 29 ¹ / ₂	MU1624		285,38 629.00	0,497 17.60
 + APP (x2)							
8/10	280 110 ¹ / ₄	120 47 ¹ / ₄	75 29 ¹ / ₂	MU1628		298,48 658.00	0,531 18.80
10	320 126"	120 47 ¹ / ₄	75 29 ¹ / ₂	MU1632		311,58 687.00	0,565 20.00
12	360 141 ³ / ₄	120 47 ¹ / ₄	75 29 ¹ / ₂	MU1636		367,94 811.00	0,645 22.80

Tavolo riunione a botte: Fenix (F), Fenix con inserto centrale rivestito in pelle (F + Cat. P)

Barrel-shaped meeting table: Fenix (F), Fenix with leather upholstered central insert (F + Cat. P)

Table réunion en forme de tonneau: Fenix (F), Fenix avec insert central revêtu en cuir (F + Cat. P)

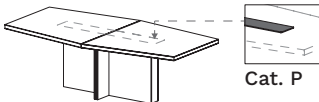
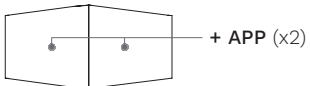
	L. W.	P. D.	H. H.	COD.		kg lb	m ³ ft ³
 Cat. P							
F 8	240 94 ¹ / ₂	120 47 ¹ / ₄	75 29 ¹ / ₂	MU1824		285,38 629.00	0,497 17.60
 + APP (x2)							
8/10	280 110 ¹ / ₄	120 47 ¹ / ₄	75 29 ¹ / ₂	MU1828		298,48 658.00	0,531 18.80
10	320 126"	120 47 ¹ / ₄	75 29 ¹ / ₂	MU1832		311,58 687.00	0,565 20.00
12	360 141 ³ / ₄	120 47 ¹ / ₄	75 29 ¹ / ₂	MU1836		367,94 811.00	0,645 22.80

Elemento intermedio per tavolo riunione: Fenix (F), Fenix con inserto centrale rivestito in pelle (F + Cat. P)

Intermediate element for meeting table: Fenix (F), Fenix with leather upholstered central insert (F + Cat. P)

Élément intermédiaire pour table réunion: Fenix (F), Fenix avec insert central revêtu en cuir (F + Cat. P)

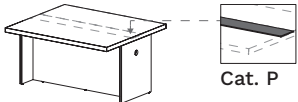
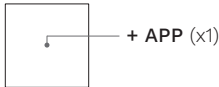
	L. W.	P. D.	H. H.	COD.		kg lb	m ³ ft ³
 Cat. P							
F 4	144 56 ³ / ₄	120 47 ¹ / ₄	75 29 ¹ / ₂	MU2614		161,82 357.00	0,332 11.70
 + APP (x1)							

Maggiorazioni - Supplement - Supplément

Foratura per piano per 1 VERSATURN (non incluso)

Drilling for top for 1 VERSATURN (not included)
Perçage pour plateau pour 1 VERSATURN (pas inclus)

APP

Foratura per piano per 1 VERSALIFT (non incluso)

Drilling for top for 1 VERSALIFT (not included)
Perçage pour plateau pour 1 VERSALIFT (pas inclus)

APP

HELORUS

Tavolo riunione: legno (W), legno con inserto centrale rivestito in pelle (W + Cat. P)



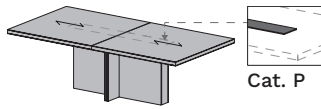

Meeting table: veneer (W), veneer with leather upholstered central insert (W + Cat. P)

Table réunion: bois (W), bois avec insert central revêtu en cuir (W + Cat. P)

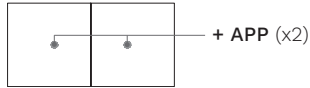

W



	L. W.	P. D.	H. H.	COD.		kg lb	m ³ ft ³
 8	240 94 ¹ / ₂	120 47 ¹ / ₄	75 29 ¹ / ₂	MU1624		287,66 634.00	0,497 17.60
 8/10	280 110 ¹ / ₄	120 47 ¹ / ₄	75 29 ¹ / ₂	MU1628		300,63 663.00	0,531 18.80
 10	320 126"	120 47 ¹ / ₄	75 29 ¹ / ₂	MU1632		313,61 691.00	0,565 20.00
 12	360 141 ³ / ₄	120 47 ¹ / ₄	75 29 ¹ / ₂	MU1636		369,43 814.00	0,645 22.80

Tavolo riunione a botte: legno (W), legno con inserto centrale rivestito in pelle (W + Cat. P)



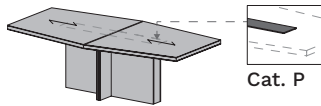

Barrel-shaped meeting table: veneer (W), veneer with leather upholstered central insert (W + Cat. P)

Table réunion en forme de tonneau: bois (W), bois avec insert central revêtu en cuir (W + Cat. P)

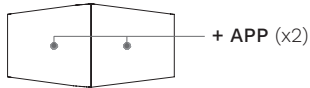

W



	L. W.	P. D.	H. H.	COD.		kg lb	m ³ ft ³
 8	240 94 ¹ / ₂	120 47 ¹ / ₄	75 29 ¹ / ₂	MU1824		277,50 612.00	0,497 17.60
 8/10	280 110 ¹ / ₄	120 47 ¹ / ₄	75 29 ¹ / ₂	MU1828		288,79 637.00	0,531 18.80
 10	320 126"	120 47 ¹ / ₄	75 29 ¹ / ₂	MU1832		300,07 662.00	0,565 20.00
 12	360 141 ³ / ₄	120 47 ¹ / ₄	75 29 ¹ / ₂	MU1836		354,20 781.00	0,645 22.80

Elemento intermedio per tavolo riunione: legno (W), legno con inserto centrale rivestito in pelle (W + Cat. P)

Intermediate element for meeting table: veneer (W), veneer with leather upholstered central insert (W + Cat. P)

Élément intermédiaire pour table réunion: bois (W), bois avec insert central revêtu en cuir (W + Cat. P)

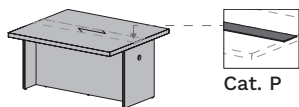

W

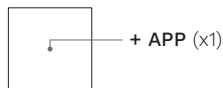

	L. W.	P. D.	H. H.	COD.		kg lb	m ³ ft ³
 4	144 56 ³ / ₄	120 47 ¹ / ₄	75 29 ¹ / ₂	MU2614		163,09 360.00	0,332 11.70

Maggiorazioni - Supplement - Supplément			
Foratura per piano per 1 VERSATURN (non incluso) Drilling for top for 1 VERSATURN (not included) Perçage pour plateau pour 1 VERSATURN (pas inclus)	APP		
Foratura per piano per 1 VERSALIFT (non incluso) Drilling for top for 1 VERSALIFT (not included) Perçage pour plateau pour 1 VERSALIFT (pas inclus)	APP		

HELORUS

Tavolo riunione: modulo in Fenix + modulo in legno (F + W), modulo in Fenix + modulo in legno e inserto centrale rivestito in pelle (F + W + Cat. P)



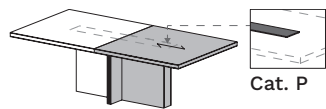

Meeting table: Fenix module + veneer module (F + W), Fenix module + veneer module and leather upholstered central insert (F + W + Cat. P)

Table réunion: module en Fenix + module en bois (F + W), module en Fenix + module en bois et insert central revêtu en cuir (F + W + Cat. P)

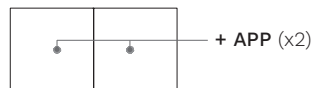

F + W



	L. W.	P. D.	H. H.	COD.		kg lb	m ³ ft ³
	240 94 ¹ / ₂	120 47 ¹ / ₄	75 29 ¹ / ₂	MU1624		286,52 632.00	0,497 17.60
	280 110 ¹ / ₄	120 47 ¹ / ₄	75 29 ¹ / ₂	MU1628		299,55 660.00	0,531 18.80
	320 126"	120 47 ¹ / ₄	75 29 ¹ / ₂	MU1632		312,59 689.00	0,565 20.00
	360 141 ³ / ₄	120 47 ¹ / ₄	75 29 ¹ / ₂	MU1636		368,69 813.00	0,645 22.80

Tavolo riunione a botte: modulo in Fenix + modulo in legno (F + W), modulo in Fenix + modulo in legno e inserto centrale rivestito in pelle (F + W + Cat. P)



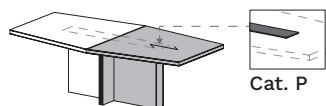

Barrel-shaped meeting table: Fenix module + veneer module (F + W), Fenix module + veneer module and leather upholstered central insert (F + W + Cat. P)

Table réunion en forme de tonneau: module en Fenix + module en bois (F + W), module en Fenix + module en bois et insert central revêtu en cuir (F + W + Cat. P)

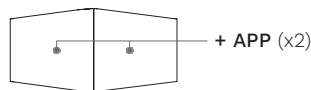

F + W



	L. W.	P. D.	H. H.	COD.		kg lb	m ³ ft ³
	240 94 ¹ / ₂	120 47 ¹ / ₄	75 29 ¹ / ₂	MU1824		281,44 620.00	0,497 17.60
	280 110 ¹ / ₄	120 47 ¹ / ₄	75 29 ¹ / ₂	MU1828		293,63 647.00	0,531 18.80
	320 126"	120 47 ¹ / ₄	75 29 ¹ / ₂	MU1832		305,82 674.00	0,565 20.00
	360 141 ³ / ₄	120 47 ¹ / ₄	75 29 ¹ / ₂	MU1836		361,07 796.00	0,645 22.80

Maggiorazioni - Supplement - Supplément

Foratura per piano per 1 VERSATURN (non incluso)
Drilling for top for 1 VERSATURN (not included)
Perçage pour plateau pour 1 VERSATURN (pas inclus)

APP

Foratura per piano per 1 VERSALIFT (non incluso)
Drilling for top for 1 VERSALIFT (not included)
Perçage pour plateau pour 1 VERSALIFT (pas inclus)

APP

HELORUS

Elemento intermedio per tavolo riunione: Fenix (F), Fenix con inserto centrale rivestito in pelle (F + Cat. P)

Intermediate element for meeting table: Fenix (F), Fenix with leather upholstered central insert (F + Cat. P)

Élément intermédiaire pour table réunion: Fenix (F), Fenix avec insert central revêtu en cuir (F + Cat. P)

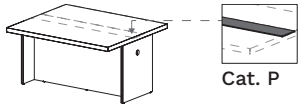

F

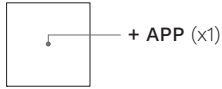

	L. W.	P. D.	H. H.	COD.		kg lb	m ³ ft ³
 4	144 56"3/4	120 47"1/4	75 29"1/2	MU2614		161,82 357.00	0,332 11.70

Elemento intermedio per tavolo riunione: legno (W), legno con inserto centrale rivestito in pelle (W + Cat. P)

Intermediate element for meeting table: veneer (W), veneer with leather upholstered central insert (W + Cat. P)

Élément intermédiaire pour table réunion: bois (W), bois avec insert central revêtu en cuir (W + Cat. P)

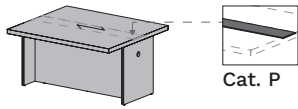

W

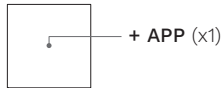

	L. W.	P. D.	H. H.	COD.		kg lb	m ³ ft ³
 4	144 56"3/4	120 47"1/4	75 29"1/2	MU2614		163,09 360.00	0,332 11.70

Maggiorazioni - Supplement - Supplément			
Foratura per piano per 1 VERSATURN (non incluso) Drilling for top for 1 VERSATURN (not included) Perçage pour plateau pour 1 VERSATURN (pas inclus)	APP		
Foratura per piano per 1 VERSALIFT (non incluso) Drilling for top for 1 VERSALIFT (not included) Perçage pour plateau pour 1 VERSALIFT (pas inclus)	APP		

HELORUS

Tavolo riunione a botte P. 160 cm: Fenix (F), Fenix con inserto centrale rivestito in pelle (F + Cat. P)

D. 63" barrel-shaped meeting table: Fenix (F), Fenix with leather upholstered central insert (F + Cat. P)

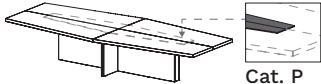
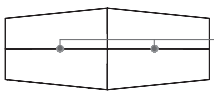
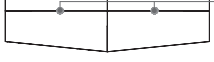

Table réunion en forme de tonneau P. 160 cm: Fenix (F), Fenix avec insert central revêtu en cuir (F + Cat. P)

	L. W.	P. D.	H. H.	COD.		kg lb	m ³ ft ³
 Cat. P							
F  + APP (x2)	12/14 400 157*1/2	160 63"	75 29*1/2	MU1890		488,70 1.08	0,881 31.10
 + APP (x2)	14 440 173*1/4	160 63"	75 29*1/2	MU1894		534,62 1.18	0,881 31.10

Elemento intermedio per tavolo riunione P. 160 cm: Fenix (F), Fenix con inserto centrale rivestito in pelle (F + Cat. P)

Intermediate element for D. 63" meeting table: Fenix (F), Fenix with leather upholstered central insert (F + Cat. P)



Élément intermédiaire pour table réunion P. 160 cm: Fenix (F), Fenix avec insert central revêtu en cuir (F + Cat. P)

	L. W.	P. D.	H. H.	COD.		kg lb	m ³ ft ³
 Cat. P							
F  + APP (x1)	4 144 56*3/4	160 63"	75 29*1/2	MU2664		207,47 457.00	0,410 14.50

Tavolo riunione a botte P. 160 cm: legno (W), legno con inserto centrale rivestito in pelle (W + Cat. P)

D. 63" barrel-shaped meeting table: veneer (W), veneer with leather upholstered central insert (W + Cat. P)

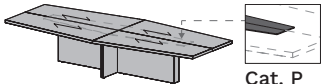
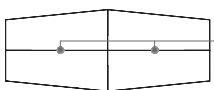

Table réunion en forme de tonneau P. 160 cm: bois (W), bois avec insert central revêtu en cuir (W + Cat. P)

	L. W.	P. D.	H. H.	COD.		kg lb	m ³ ft ³
 Cat. P							
W  + APP (x2)	12/14 400 157*1/2	160 63"	75 29*1/2	MU1890		467,48 1.03	0,881 31.10
 + APP (x2)	14 440 173*1/4	160 63"	75 29*1/2	MU1894		511,57 1.13	0,977 34.50

Elemento intermedio per tavolo riunione P. 160 cm: legno (W), legno con inserto centrale rivestito in pelle (W + Cat. P)

Intermediate element for D. 63" meeting table: veneer (W), veneer with leather upholstered central insert (W + Cat. P)

Élément intermédiaire pour table réunion P. 160 cm: bois (W), bois avec insert central revêtu en cuir (W + Cat. P)

	L. W.	P. D.	H. H.	COD.		kg lb	m ³ ft ³
 Cat. P							
W  + APP (x1)	4 144 56*3/4	160 63"	75 29*1/2	MU2664		208,38 459.00	0,410 14.50

Maggiorazioni - Supplement - Supplément

Foratura per piano per 1 VERSATURN (non incluso)
Drilling for top for 1 VERSATURN (not included)
Perçage pour plateau pour 1 VERSATURN (pas inclus)

APP

Foratura per piano per 1 VERSALIFT (non incluso)
Drilling for top for 1 VERSALIFT (not included)
Perçage pour plateau pour 1 VERSALIFT (pas inclus)

APP

HELORUS

Tavolo conferenza in Fenix (F)

Fenix conference table (F)
Table conference en Fenix (F)

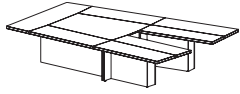

F

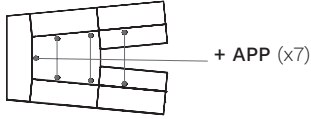

	L. W.	P. D.	H. H.	COD.		kg lb	m ³ ft ³
 10/12	383 150 ³ / ₄	270 106 ¹ / ₄	75 29 ¹ / ₂	MU3638		505,83 112	1,027 36.30

Coppia di elementi intermedi in Fenix (F) per tavolo conferenza

Pair of Fenix (F) intermediate elements for conference table
Paire de éléments intermédiaires en Fenix (F) pour table conference

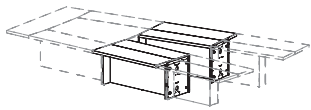

F

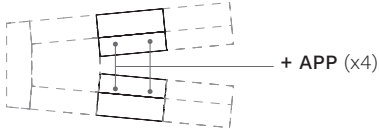

	L. W.	P. D.	H. H.	COD.		kg lb	m ³ ft ³
	160 63"	100 39 ³ / ₈	75 29 ¹ / ₂	MU3616		250,60 552.00	0,502 17.70

Tavolo conferenza in legno (W)

Veneer conference table (W)
Table conference en bois (W)

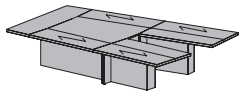

W

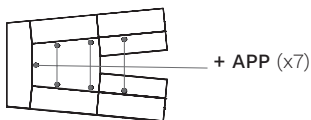

	L. W.	P. D.	H. H.	COD.		kg lb	m ³ ft ³
 10/12	383 150 ³ / ₄	270 106 ¹ / ₄	75 29 ¹ / ₂	MU3638		514,35 113	1,028 36.30

Coppia di elementi intermedi in legno (W) per tavolo conferenza

Pair of veneer (W) intermediate elements for conference table
Paire de éléments intermédiaires en bois (W) pour table conference

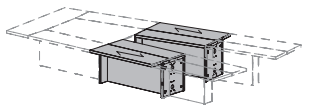

W

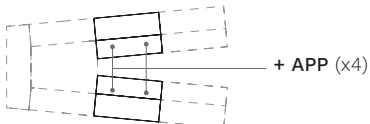

	L. W.	P. D.	H. H.	COD.		kg lb	m ³ ft ³
	160 63"	300 118 ¹ / ₈	75 29 ¹ / ₂	MU3616		263,00 580.00	0,502 17.70

Maggiorazioni - Supplement - Supplément

Foratura per piano per 1 VERSALIFT (non incluso)
Drilling for top for 1 VERSALIFT (not included)
Perçage pour plateau pour 1 VERSALIFT (pas inclus)

APP

HELORUS

Tavolo conferenza in legno con inserto in Fenix (W + F)

Veneer conference table with Fenix insert (W + F)

Table conference en bois avec insert en Fenix (W + F)

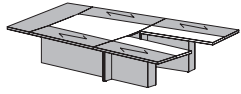

W + F

	L. W.	P. D.	H. H.	COD.		kg lb	m ³ ft ³
 10/12	383 150 ³ / ₄	270 106 ¹ / ₄	75 29 ¹ / ₂	MU3638		521,93 115	1,028 36.30

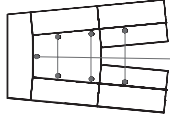

+ APP (x7)

Coppia di elementi intermedi in legno con inserto in Fenix (W + F) per tavolo conferenza

Pair of veneer intermediate elements with Fenix insert (W + F) for conference table

Paire de éléments intermédiaires pour table conférence en bois avec insert en Fenix (W + F)

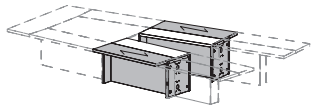

W + F

	L. W.	P. D.	H. H.	COD.		kg lb	m ³ ft ³
	160 63"	300 118 ¹ / ₈	75 29 ¹ / ₂	MU3616		263,40 581.00	0,502 17.70

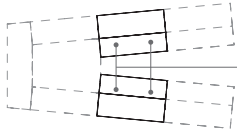

+ APP (x4)

Maggiorazioni - Supplement - Supplément

Foratura per piano per 1 VERSALIFT (non incluso)
Drilling for top for 1 VERSALIFT (not included)
Perçage pour plateau pour 1 VERSALIFT (pas inclus)

APP

Vasca raccogliacavi per tavolo conferenza

Cable tray for conference table

Porte-câbles pour table conférence

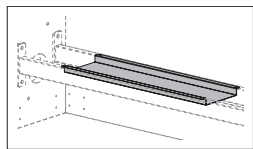

	L. W.	P. D.	H. H.	COD.		kg lb	m ³ ft ³
	50 19 ⁵ / ₈	15,6 6 ¹ / ₈	2 3/4"	MU9205		1,00 2.20	0,004 0.14

HELORUS

Tavolino caffè con piano quadrato in Fenix (F)

Fenix (F) coffee table with square top
Table basse avec plateau carré en Fenix (F)



L. W.	P. D.	H. H.	COD.	kg lb	m ³ ft ³
60 23 ⁵ / ₈	60 23 ⁵ / ₈	30 11 ³ / ₄	MU1606	19,24 42.40	0,048 1.70

Tavolino caffè con piano rettangolare in Fenix (F)

Fenix (F) coffee table with rectangular top
Table basse avec plateau rectangulaire en Fenix (F)

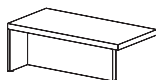

L. W.	P. D.	H. H.	COD.	kg lb	m ³ ft ³
120 47 ¹ / ₄	60 23 ⁵ / ₈	45 17 ³ / ₄	MU1612	37,26 82.10	0,095 3.35

Tavolino caffè con piano quadrato in legno (W)

Veneer (W) coffee table with square top
Table basse avec plateau carré en bois (W)

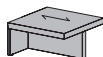

L. W.	P. D.	H. H.	COD.	kg lb	m ³ ft ³
60 23 ⁵ / ₈	60 23 ⁵ / ₈	30 11 ³ / ₄	MU1606	18,98 41.80	0,047 1.66

Tavolino caffè con piano rettangolare in legno (W)

Veneer (W) coffee table with rectangular top
Table basse avec plateau rectangulaire en bois (W)

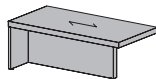

L. W.	P. D.	H. H.	COD.	kg lb	m ³ ft ³
120 47 ¹ / ₄	60 23 ⁵ / ₈	45 17 ³ / ₄	MU1612	36,71 80.90	0,094 3.32

Tavolino caffè con piano quadrato: Hpl (HL), laccato opaco (LA)

Coffee table with square top: Hpl (HL), matt lacquered (LA)
Table basse avec plateau carré: Hpl (HL), laqué mat (LA)



L. W.	P. D.	H. H.	COD.	kg lb	m ³ ft ³
60 23 ⁵ / ₈	60 23 ⁵ / ₈	30 11 ³ / ₄	MU1606	24,82 54.70	0,065 2.30

Tavolino caffè con piano rettangolare: Hpl (HL), laccato opaco (LA)

Coffee table with rectangular top: Hpl (HL), matt lacquered (LA)
Table basse avec plateau rectangulaire: Hpl (HL), laqué mat (LA)

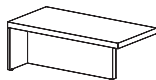

L. W.	P. D.	H. H.	COD.	kg lb	m ³ ft ³
120 47 ¹ / ₄	60 23 ⁵ / ₈	45 17 ³ / ₄	MU1612	36,48 80.40	0,095 3.35

HELORUS

Madia con 2 cassetti: Fenix (F), Hpl (HL), laccato opaco (LA), Oleomalta (OM)

Cupboard with 2 drawers: Fenix (F), Hpl (HL), matt lacquered (LA), Oleomalta (OM)

Armoire avec 2 tiroirs: Fenix (F), Hpl (HL), laqué mat (LA), Oleomalta (OM)

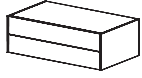

L. W.	P. D.	H. H.	COD.	kg lb	m ³ ft ³
102 40 ¹ / ₈	59 23 ¹ / ₄	35 13 ³ / ₄	MU11102	52,16 115.00	0,225 7.93

Madia con 4 cassetti: Fenix (F), Hpl (HL), laccato opaco (LA), Oleomalta (OM)

Cupboard with 4 drawers: Fenix (F), Hpl (HL), matt lacquered (LA), Oleomalta (OM)

Armoire avec 4 tiroirs: Fenix (F), Hpl (HL), laqué mat (LA), Oleomalta (OM)



L. W.	P. D.	H. H.	COD.	kg lb	m ³ ft ³
202 79 ¹ / ₂	59 23 ¹ / ₄	35 13 ³ / ₄	MU13102	99,48 219.00	0,519 18.30

Fioriera (non a tenuta stagna): Fenix (F), Hpl (HL), laccato opaco (LA), Oleomalta (OM)

Plant box (not leakproof): Fenix (F), Hpl (HL), matt lacquered (LA), Oleomalta (OM)

Bac à fleur (non étanche): Fenix (F), Hpl (HL), laqué mat (LA), Oleomalta (OM)

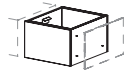

L. W.	P. D.	H. H.	COD.	kg lb	m ³ ft ³
50 19 ⁵ / ₈	59 23 ¹ / ₄	35 13 ³ / ₄	MU10103	28,61 63.10	0,156 5.50

Madia con 4 cassetti: Fenix (F), Hpl (HL), laccato opaco (LA), Oleomalta (OM)

Cupboard with 4 drawers: Fenix (F), Hpl (HL), matt lacquered (LA), Oleomalta (OM)

Armoire avec 4 tiroirs: Fenix (F), Hpl (HL), laqué mat (LA), Oleomalta (OM)

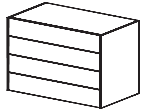

L. W.	P. D.	H. H.	COD.	kg lb	m ³ ft ³
102 40 ¹ / ₈	59 23 ¹ / ₄	69 27 ¹ / ₈	MU31102	103,05 227.00	0,489 17.30

Madia con 8 cassetti: Fenix (F), Hpl (HL), laccato opaco (LA), Oleomalta (OM)

Cupboard with 8 drawers: Fenix (F), Hpl (HL), matt lacquered (LA), Oleomalta (OM)

Armoire avec 8 tiroirs: Fenix (F), Hpl (HL), laqué mat (LA), Oleomalta (OM)



L. W.	P. D.	H. H.	COD.	kg lb	m ³ ft ³
202 79 ¹ / ₂	59 23 ¹ / ₄	69 27 ¹ / ₈	MU33102	197,82 436.00	0,958 33.80

Fioriera (non a tenuta stagna): Fenix (F), Hpl (HL), laccato opaco (LA), Oleomalta (OM)

Plant box (not leakproof): Fenix (F), Hpl (HL), matt lacquered (LA), Oleomalta (OM)

Bac à fleur (non étanche): Fenix (F), Hpl (HL), laqué mat (LA), Oleomalta (OM)

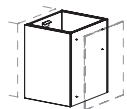

L. W.	P. D.	H. H.	COD.	kg lb	m ³ ft ³
50 19 ⁵ / ₈	59 23 ¹ / ₄	69 27 ¹ / ₈	MU30103	49,78 110.00	0,183 6.46

HELORUS

Madia con 2 ante: Fenix (F), Hpl (HL), laccato opaco (LA), Oleomalta (OM)
 Cupboard with 2 doors: Fenix (F), Hpl (HL), matt lacquered (LA), Oleomalta (OM)
 Armoire avec 2 portes: Fenix (F), Hpl (HL), laqué mat (LA), Oleomalta (OM)

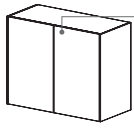

+ LOCK 
 Type D

L. W.	P. D.	H. H.	COD.
102 40 ¹ / ₈	48 18 ⁷ / ₈	82 32 ¹ / ₄	MU41001

kg lb	m ³ ft ³
71,65 158.00	0,723 25.50

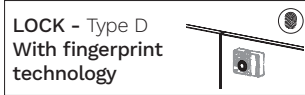

Maggiorazioni - Supplement - Supplément			
Serratura con tecnologia a impronta digitale Lock with fingerprint technology Serrure à empreinte digitale	LOCK Type D		

Madia con 4 ante: Fenix (F), Hpl (HL), laccato opaco (LA), Oleomalta (OM)
 Cupboard with 4 doors: Fenix (F), Hpl (HL), matt lacquered (LA), Oleomalta (OM)
 Armoire avec 4 portes: Fenix (F), Hpl (HL), laqué mat (LA), Oleomalta (OM)

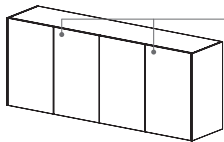

+ LOCK 
 Type D

L. W.	P. D.	H. H.	COD.
203 79 ⁷ / ₈	48 18 ⁷ / ₈	82 32 ¹ / ₄	MU43001

kg lb	m ³ ft ³
135,85 299.00	1,251 44.20

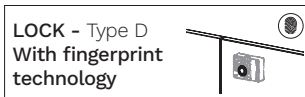

Maggiorazioni - Supplement - Supplément			
Serratura con tecnologia a impronta digitale Lock with fingerprint technology Serrure à empreinte digitale	LOCK Type D		

Fioriera (non a tenuta stagna): Fenix (F), Hpl (HL), laccato opaco (LA), Oleomalta (OM)
 Plant box (not leakproof): Fenix (F), Hpl (HL), matt lacquered (LA), Oleomalta (OM)
 Bac à fleur (non étanche): Fenix (F), Hpl (HL), laqué mat (LA), Oleomalta (OM)

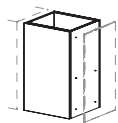

L. W.	P. D.	H. H.	COD.
50 19 ⁵ / ₈	48 18 ⁷ / ₈	82 32 ¹ / ₄	MU40003

kg lb	m ³ ft ³
50,82 112.00	0,188 6.65

HELORUS

Madia con 2 ante: Fenix (F), Hpl (HL), laccato opaco (LA), Oleomalta (OM)

Cupboard with 2 doors: Fenix (F), Hpl (HL), matt lacquered (LA), Oleomalta (OM)

Armoire avec 2 portes: Fenix (F), Hpl (HL), laqué mat (LA), Oleomalta (OM)

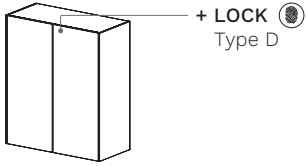

L. W.	P. D.	H. H.	COD.		kg lb	m ³ ft ³
102 40 ¹ / ₈	48 18 ⁷ / ₈	120 47 ¹ / ₄	MU51001		93,98 207.00	0,970 34.20



Maggiorazioni - Supplement - Supplément

Serratura con tecnologia a impronta digitale

Lock with fingerprint technology
Serrure à empreinte digitale

LOCK

Type D

Madia con 4 ante: Fenix (F), Hpl (HL), laccato opaco (LA), Oleomalta (OM)

Cupboard with 4 doors: Fenix (F), Hpl (HL), matt lacquered (LA), Oleomalta (OM)

Armoire avec 4 portes: Fenix (F), Hpl (HL), laqué mat (LA), Oleomalta (OM)

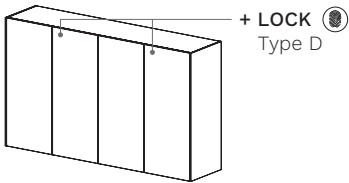

L. W.	P. D.	H. H.	COD.		kg lb	m ³ ft ³
202 79 ¹ / ₂	48 18 ⁷ / ₈	120 47 ¹ / ₄	MU53001	3.873	177,48 391.00	1,656 58.50



Maggiorazioni - Supplement - Supplément

Serratura con tecnologia a impronta digitale

Lock with fingerprint technology
Serrure à empreinte digitale

LOCK

Type D

Fioriera (non a tenuta stagna): Fenix (F), Hpl (HL), laccato opaco (LA), Oleomalta (OM)

Plant box (not leakproof): Fenix (F), Hpl (HL), matt lacquered (LA), Oleomalta (OM)

Bac à fleur (non étanche): Fenix (F), Hpl (HL), laqué mat (LA), Oleomalta (OM)

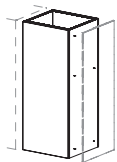

L. W.	P. D.	H. H.	COD.		kg lb	m ³ ft ³
50 19 ⁵ / ₈	48 18 ⁷ / ₈	120 47 ¹ / ₄	MU50003		66,59 147.00	0,223 7.88

HELORUS

Mensola: Fenix (F), Hpl (HL), legno (W)

Shelf: Fenix (F), Hpl (HL), veneer (W)

Étagère: Fenix (F), Hpl (HL), bois (W)



Dx
Rh

	L. W.	P. D.	H. H.	COD.		kg lb	m ³ ft ³
Dx Rh	80 31 ¹ / ₂	25 9 ⁷ / ₈	10 3 ⁷ / ₈	MU0708D		3,78 8.33	0,027 0.94
Sx Lh	80 31 ¹ / ₂	25 9 ⁷ / ₈	10 3 ⁷ / ₈	MU0708S		3,78 8.33	0,027 0.94
Dx Rh	120 47 ¹ / ₄	25 9 ⁷ / ₈	10 3 ⁷ / ₈	MU0712D		5,28 11.60	0,039 1.38
Sx Lh	120 47 ¹ / ₄	25 9 ⁷ / ₈	10 3 ⁷ / ₈	MU0712S		5,28 11.60	0,039 1.38